

**HILGER
CATALOGUE
E
SPECTROGRAPHS**

**JULY
1937**

ADAM HILGER LTD., OPTICAL INSTRUMENT MAKERS

98 KINGS ROAD, CAMDEN ROAD, LONDON, N.W.1., ENGLAND



CATALOGUE E

SPECTROGRAPHS

The manufacture of the Optical Work of our Spectrometers and Spectrographs is controlled by the use in our workshops and testing-rooms of the Hilger Interferometers mentioned in Catalogue N. See also "New Standards of Perfection in Lenses," post free on request.

| INSTRUMENTS | PAGES |
|--|-------------|
| Large Quartz Spectrographs F_0 170 cms. | E 2-10 |
| Large Glass Spectrographs F_0 170 cms. | E 5-6, E 10 |
| Medium Quartz Spectrographs F_0 60 cms. | E 11-14 |
| Medium Glass Spectrographs F_0 60 cms. | E 14-15 |
| Infra-Red Spectrographs | E 15 |
| Intermediate Quartz Spectrographs F_0 38 cms. | E 16 |
| Small Quartz Spectrographs F_0 20 cms. | E 17-18 |
| Table of Dispersions of above Spectrographs | E 19 |
| Large Aperture Quartz Spectrographs | E 20-21 |
| Glass Littrow Spectrographs | E 22 and 27 |
| Large Aperture Glass Spectrographs | E 22-25 |
| Compound D.V. Dispenser | E 25-27 |
| Astronomical Spectrographs | E 28 |
| Interchangeable Spectrographs | E 29-37 |
| Grating Spectrographs | E 38-39 |
| Fluorescence Spectrograph | E 40 |
| Vacuum Spectrographs, Grating | E 40-43 |
| Vacuum Spectrographs, Fluorite | E 43-46 |
| Vacuum Arc Lamps | E 46-47 |
| Dexrac Industrial X-ray Unit | E 48-49 |
| X-ray Crystallograph | E 50-51 |
| X-ray Metallurgical Crystallograph | E 51 |
| X-ray Spectrograph, Laby | E 52-53 |
| X-ray Spectrograph, Müller | E 54-58 |
| Index | E 59-60 |

Other apparatus is described elsewhere as follows:

| | |
|---|----------------------|
| Astronomical Spectrographs | Catalogue G |
| Spectropolarimeters for the Ultra Violet | Publication No. 242 |
| Spectrophotometers for the Ultra Violet | Catalogue H and 156. |
| Refractometers for the Ultra Violet | Catalogue M |

The copyright of this Catalogue, with its letterpress and illustrations, is protected by the Copyright Act, 1911.

ADAM HILGER, Ltd., 98 Kings Road, Camden Road, London, N.W. 1

July, 1937



Fig. E 492b. Detail of Wavelength Range Drum.

Adjustable cut-off control knob and scale.

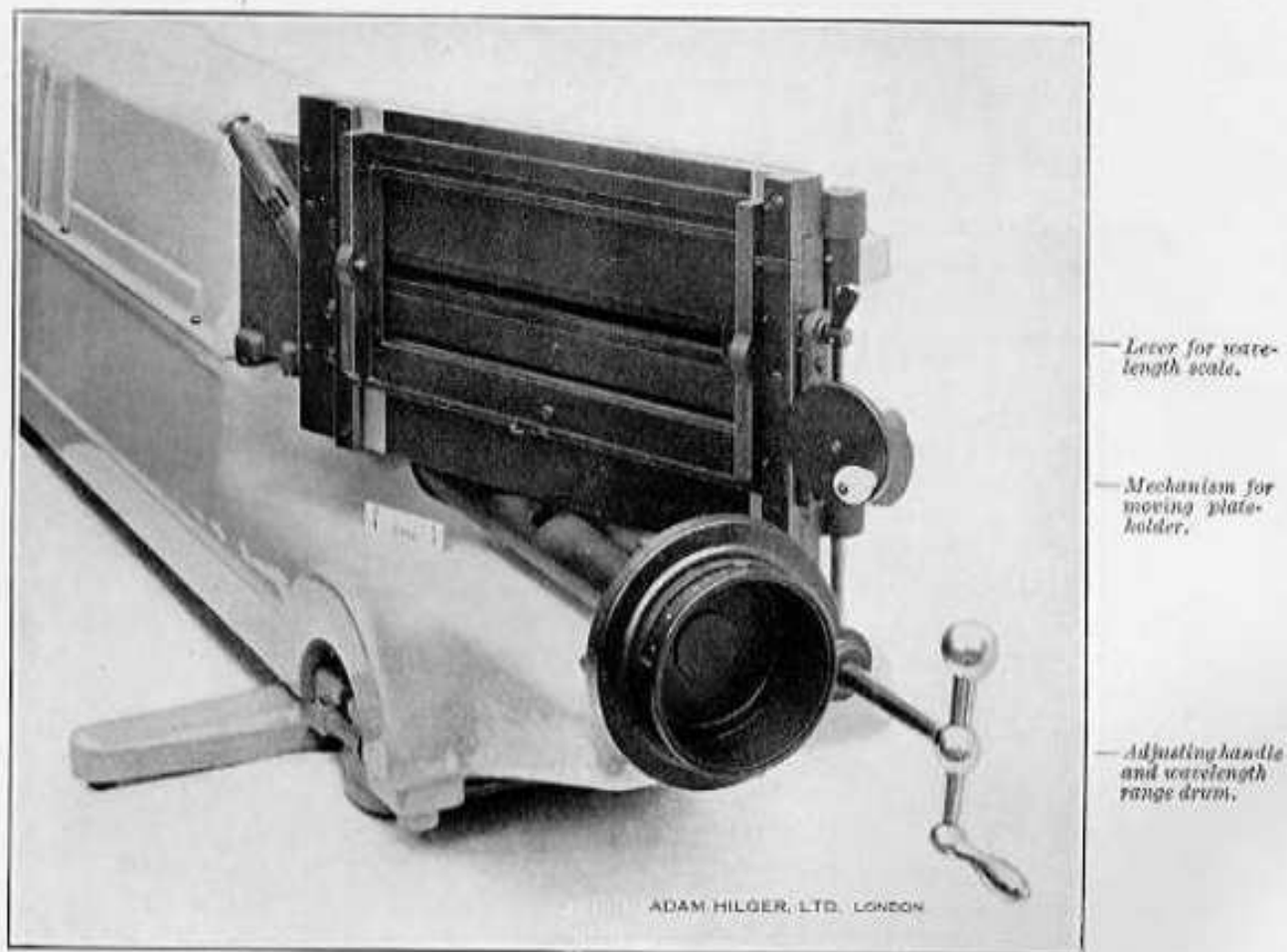

Fig. E 492a. Camera end of Automatic Large Quartz Spectrograph.

LARGE SPECTROGRAPHS

F_D 170 CMS.

(For Glass Spectrographs F_D 170 cms., see pages E 5-6, 10. For dispersion see p. E 19.)

LARGE FULLY AUTOMATIC QUARTZ SPECTROGRAPH

F_D 170 cms.

BARFIT * MODEL

RANGE 1910A TO 8000A

LARGE Quartz Spectrographs whose dispersion is such that the complete range of spectrum has to be taken in several separate exposures require three independent adjustments for each portion of the spectrum. In the Hilger Automatic Large Spectrograph, for the first time, all these adjustments are under the control of a single handle. Furthermore, the wavelength range included on the photographic plate at any setting is automatically indicated on an engraved drum. The adjusting handle and drum are situated at the same end of the instrument as the plateholder and the slit, and are always accessible without opening any part of the instrument and without the operator having to move from his place at the slit end of the instrument.

The advantages resulting from this design are numerous and very important :

1. The operator is not restricted to the use of a few selected spectral range settings, but can, without loss of time, select *any* region of the spectrum he desires to include on his plate. He is at once sure that the range selected will be in correct focus over the whole length of the plate, without further adjustment of any kind. The ability to choose *any* spectrum range often permits of one exposure performing the function of two on the earlier instruments. Any number of different ranges can be recorded on the one plate.

2. Time is saved in those cases in which the lines of interest cannot all be included in a single spectrum range, since readjustment for a fresh range is made instantaneously.

3. It is *impossible* to waste exposures through forgetting to perform one or other of the adjustments which it was necessary to perform on earlier instruments.

4. Often in routine work only a small range of spectrum needs to be photographed and in such cases the construction of the plateholder enables economy in material to be exercised by permitting the insertion of short lengths of plate (provided they are four inches high) at any desired position in its length.

5. Provision is made for the addition of a rigid and accurately aligned bar, of standard section, by means of which accessories can be instantly placed in correct alignment in front of the slit.

* The word Barfit is registered as a Trade Mark in Great Britain and U.S.A.

ADAM HILGER, Ltd., 98 Kings Road, Camden Road, London, N.W. 1

The optical specification is identical with that of its earlier non-automatic prototypes, which have long been familiar as Hilger size D., Hilger E 1, Hilger E 384 and Hilger Large Quartz Spectrograph. Briefly it is as follows :

Lens. Of crystalline quartz, focal length for D, 170 cms., diameter 75 mm.

Dispersing System. One prism of crystalline quartz, refracting angle 30° , length of refracting face 93 to 96 mm.

BRIEF MECHANICAL SPECIFICATION

Construction. All metal.

Slit. F 31 Type, with stainless steel jaws ; fine screw adjustment ; three aperture diaphragm and wedge diaphragm ; shutter behind jaws.

Size of Plate. 10 × 4 in. (25.4 × 10.2 cms.). Plateholder has worm operated rack and pinion movement. Some 50 to 60 spectra may be taken on one plate. 10 × 2 in. or 9 × 24 cms. plateholders can be supplied on request.

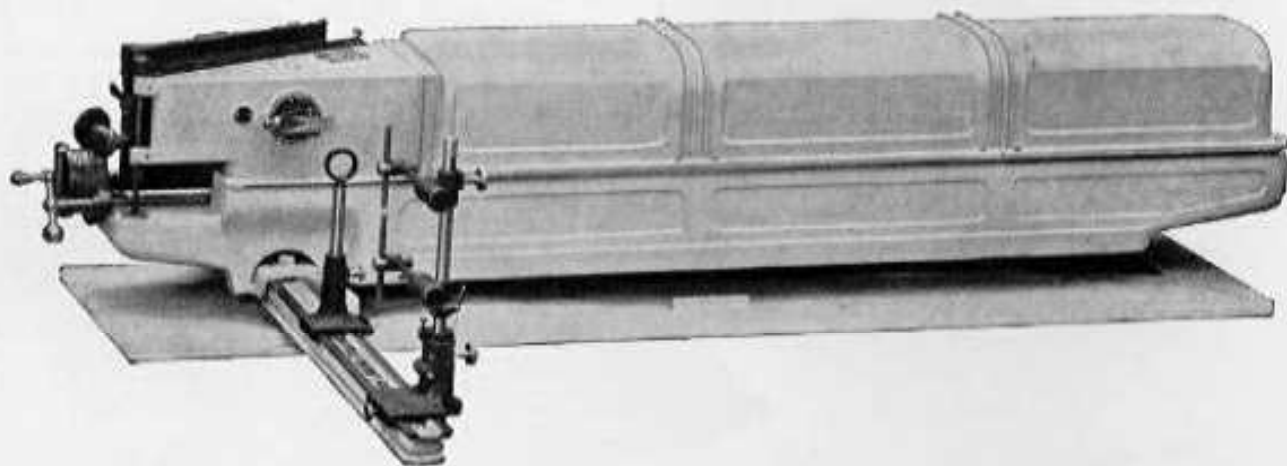

Fig. E 492

Range of Spectrum. 1910 Å to 8000 Å.

Length of Spectrum. From 2000 Å to 8000 Å, 67 cms.

Scale. A millimetre scale is so mounted inside that it may easily be printed on the negative together with the spectrum.

Bar. The Hilger Standard Accessory Bar which can be fitted to this spectrograph ensures accurate alignment of the spectrograph with its accessories and holds them rigidly.

It is worthy of note that the full aperture of this instrument is used so that the highest resolving power is obtained and the speed is unequalled. The amount of fog (always incidental in the Littrow system) is, even with this full aperture, quite negligible for the purposes of spectrum analysis, owing to the careful attention that has been given in the design to its elimination. (For certain special physical investigations the additional precaution of a narrow anti-fog strip is provided as has been done for many years in the Hilger instruments.)

ADAM HILGER, Ltd., 98 Kings Road, Camden Road, London, N.W. 1

For such work as spectrophotometry it is occasionally desirable to avoid even the slightest amount of fog above and below the spectrum. For this reason the camera back is provided with two cut-off blades which are set at the width of the spectrum by means of a knurled knob and scale. These blades are interlocked with the scale mechanism so that they open to give passage to the scale mount and afterwards close again to the pre-set separation.

The raising and lowering motion for the plateholder is one which has been found very effective on our new medium spectrograph. It gives positive control over the movement of the plateholder and is very easy to operate. A spring "click" gives accurate spacing at millimetre intervals. A three-millimetre scale is engraved on the plateholder slide.

E 492.—Hilger Barfit Automatic Large Quartz Spectrograph ...

E 481.—Hilger Standard Accessory Bar, 42 ins. long

E 482.—Short Bar, 21 ins. long, for carrying accessories not in use

For further details and accessories see Publication Nos. 232 and 107.

For extra plateholders see page E 10.

LARGE QUARTZ AND GLASS LITTROW SPECTROGRAPH WITH FULLY AUTOMATIC ADJUSTMENT

BARFIT* MODEL

Range for Glass 3700 Å to 12,000 Å

Range for Quartz 1910 Å to 8,000 Å.

A second model of the large automatic quartz spectrograph already described differs from the first in that it is supplied with automatically interchangeable glass and quartz optical systems.

Separate scales indicating the wavelength range in action are provided for the glass and for the quartz trains. When the "glass" wavelength scale is visible, then the glass train is in operation. By the simple act of turning over a handle the quartz train replaces the glass train, and the "quartz" scale replaces the "glass" scale. Simultaneously the appropriate adjusting mechanism is brought into play. Thus the change from one optical train to the other can be made in two seconds without opening the instrument and without the observer quitting his place at the slit and camera end of the instrument.

Thus it becomes perfectly feasible to take *on one and the same plate*, in perfect adjustment, photographs of any desired wavelength range and using either the glass or quartz optic.

* The word Barfit is registered as a Trade Mark in Great Britain and U.S.A.

OPTICAL SPECIFICATION

QUARTZ TRAIN.

Lens, of crystalline quartz, focal length for D 170 cms., diameter 75 mm.

Dispersing System. One prism of crystalline quartz, refracting angle 30° , length of refracting face 93 to 96 mm.

Range of Spectrum 1910 Å to 8,000

Length of Spectrum From 2000 Å to 8000 Å = 67 cms.

GLASS TRAIN.

Lens, of dense flint glass, focal length for D about 170 cms., diameter 75 mm.

Dispersing System. One prism of dense flint glass, refracting angles about 26° , length of refracting face about 94 mm.

Range of Spectrum 3700 to 12,000 Å

Length of Spectrum 4000 to 8,000 Å = 32 cms.

MECHANICAL SPECIFICATION

This is identical with that of E 492 already described, with the addition of the mechanism for alternating the optical trains.

Note.—The glass optical system cannot be *added* to the E 492 type of spectrograph.

E 478.—Hilger Automatic Large Quartz and Glass Spectrograph.

With internal mm. scale

E 481.—Bar for Accessories—42 ins. long

E 482.—Short Bar—21 ins. long, for carrying accessories not in use

FULLY AUTOMATIC LARGE GLASS SPECTROGRAPH

This instrument corresponds with the foregoing but has only the glass optical system.

E 493.—Hilger Fully Automatic Glass Spectrograph, with internal

millimetre scale

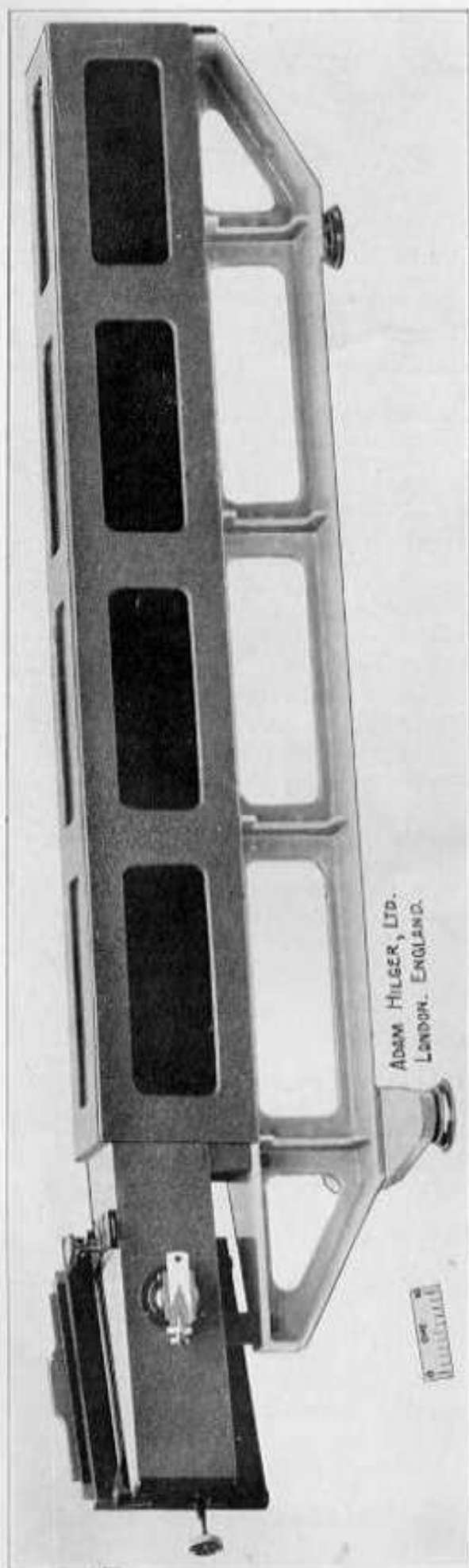

E 888

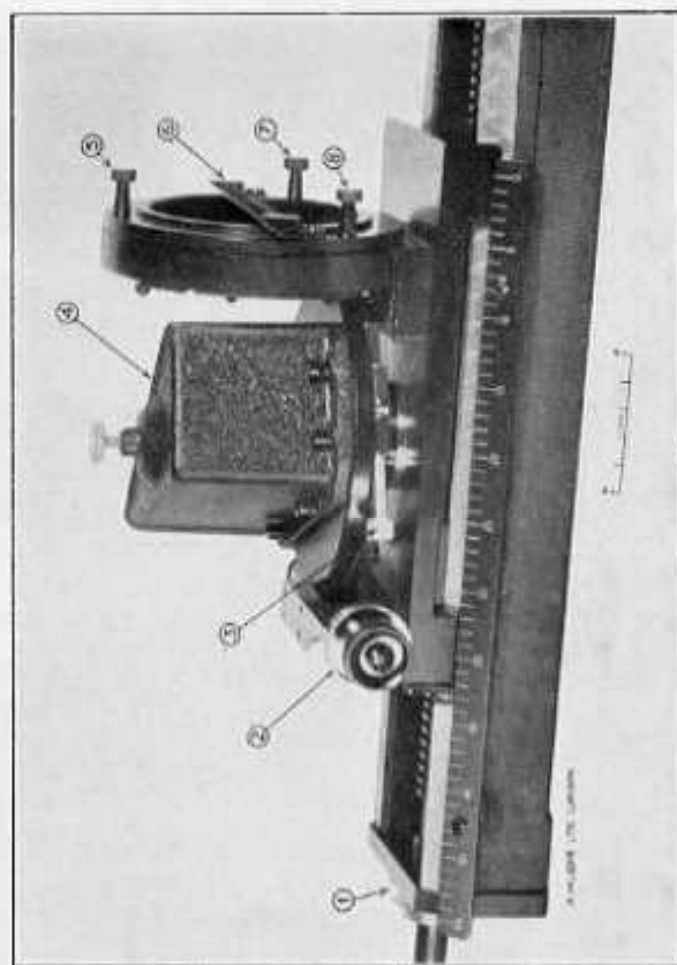

E 888 a

LARGE QUARTZ SPECTROGRAPHS F_b 170 CMS. WITHOUT AUTOMATIC ADJUSTMENT

All-Metal Quartz Spectrograph, E 383, Fig. E 383. This Spectrograph, the latest form of the well-known E 1, introduced by us as "Size D," is constructed of metal throughout. It has a dispersion three times that of E 488 (see pages E 13-14), being designed for work with complex spectra, such as that of iron. It takes the entire spectrum from 1930 Å to 8000 Å in four exposures, on 10 × 4 inch * photographic plates.

It is of "Littrow" form, which in so large an instrument presents great advantages owing to its compactness.

The optical train consists of one quartz lens of 75 mm. clear aperture, and 170 cms. focal length; and a 30° prism of quartz 93 to 96 mm. length of refracting face × 54 to 58 mm. high, the second face being coated with tin mercury amalgam, which is a good reflector throughout both the visible and ultra-violet regions.

The slit is our No. F 31 (see page F 6). The light enters by the slit, is reflected along the camera tube by a right-angled prism of quartz, is collimated by the lens, enters and is reflected back by the quartz prism, and retraces its path through the lens, an image of the spectrum being formed on the photographic plate. Light which would be directly reflected on to the photographic plate by the surfaces of the lens, thus producing fog and lessening the contrast of the spectrum lines, is removed by insertion before the lens of a strip of brass covered with black velvet, Fig. E 383a (6). The area of this strip is sufficiently small for no perceptible increase of exposure to be needed.

The prism is sheltered by a metallic cover, Fig. 383a (4). No other method has been found, as a result of many experiments, so effective in attaining rapidly the uniformity of temperature throughout the prism on which good definition largely depends.

The removal of the prism with its mount (for interchanging with the glass prism and mount E 52, for instance) is very easily effected—the screw (3) shown in Fig. E 383a is loosened, and the prism and mount (4) can at once be lifted away.

The prism and lens are mounted on a carriage which moves along a slide, its position being defined by a scale and index and drum (1). The prism can also be rotated, and its position set by a drum and index (2). The positions corresponding with the four portions of the spectrum, and the necessary inclination of the plate, are given in the instructions supplied with each instrument.

The inclination of the plate is set by means of a milled knob, a clamp also being provided to avoid accidental alteration. The way of putting the dark slide in position has recently been improved. A new geometrical construction eliminates slides or grooves and permits the plateholder to drop into position easily and accurately. It rests in a carriage which, by means of gears, raises it and lowers it at will for taking successive spectra.

The whole instrument is mounted on a substantial cast-iron base.

Overall length of spectrograph 79 inches (2000 mm.).

Overall width of spectrograph 14 inches (350 mm.).

Height to centre of instrument 12.6 inches (32 cms.).

E 383.—Large Quartz Spectrograph F_b 170 cms. (all metal) as above.

* If desired a dark slide to take plates 9 × 24 cms. can be substituted.

SCALES FOR NON-AUTOMATIC QUARTZ SPECTROGRAPHS F_D 170 CMS.

Scales for the above can also be supplied in either of the two following ways:—

- (1) Separate wavelength scales to be laid on the negatives, or prints from the negatives, for reading off the wavelengths. Four wavelength scales are supplied covering the region from 8,000 to 1,900 Å.

E 385.—Set of four wavelength scales for laying on the spectrum photograph, for use with Large Model Quartz Spectrographs of Type E 383, etc.

- (2) A scale in millimetres mounted inside the instrument and brought into operation in exactly the same way as is used for the wavelength scales of the E 488 spectrographs. For each range of spectrum calibration curves are supplied by means of which the wavelength corresponding with each millimetre can be found.

In either case the accuracy is about ± 10 Å at 3,000 Å.

E 384.—Large All-Metal Quartz Spectrograph F_D 170 cms. as E 383, but with internal millimetre scale fitted as above including calibration curves.

CONDENSERS, AND OTHER FITTINGS, FOR NON-AUTOMATIC QUARTZ SPECTROGRAPHS F_D 170 CMS.

E 371.—Condenser Attachment with Spherical Quartz Condenser for Spectrographs F_D 170 cms. The attachment consists of a tubular mount carrying a condenser the position of which is carefully adjusted at our works. The position for the light source is correct when its image is on the slit, so that the adjustment of alignment usually associated with spectrographs is eliminated and the instrument can be got into operation at once.

E 475.—Sphero-Cylindrical Condenser in Cell to interchange with spherical condenser of E 371.

E 402.—Condenser Attachment with Sphero-Cylindrical Quartz Condenser, for Spectrographs F_D 170 cms. (as E 371 above).

E 476.—Spherical Condenser in Cell to interchange with sphero-cylindrical condenser of E 402.

We strongly recommend that all non-automatic Quartz Spectrographs F_D 170 cms. should be fitted with one of the above Condenser Attachments.

EXTRA PLATEHOLDERS FOR ALL TYPES OF LARGE ALL-METAL SPECTROGRAPHS F_n 170 CMS.

On all spectrographs supplied after July 1934 the plateholders are interchangeable and extra ones can be supplied on demand.

E 468.—Extra Plateholder for 10" × 4" Plates for Spectrographs E 492, E 478, E 383, 384 and E 391, 401, etc. (see below).

E 469.—Extra Plateholder for 10" × 2" Plates for Spectrographs E 492, E 478, E 383, 384 and E 391, 401, etc. (see below).

GLASS PRISMS AND LENSES FOR NON-AUTOMATIC SPECTROGRAPHS F_n 170 CMS.

See pages E 5-6 for description of fully automatic Large Quartz and Glass Spectrograph.

We can supply any of the foregoing non-automatic Spectrographs with additional glass systems, consisting of a lens and a prism, to replace the quartz train already fitted, thereby increasing the dispersion of the instrument in the visible and near ultra-violet regions. Similar Spectrographs, which have only the glass optical system, can also be supplied.

E 52.—Dense Glass Prism and Lens to interchange with the quartz prism and lens of E 383, E 1, etc. (*Not for use with the fully automatic Spectrograph E 492.*) The spectrum extends from 12,000 Å to 3800 Å and from 9000 to 4000 Å, is about 34 cms. long, and can be photographed in two settings. (See Catalogue F and Hilger Publication No. 179 for special Kodak plates for the infra-red.)

The lens is in a cell readily interchangeable with the cell containing the quartz lens.

The prism is mounted with a cover on its own separate table which can be interchanged with the table bearing the quartz prism without any loss of adjustment, as described on page E 8.

LARGE GLASS NON-AUTOMATIC SPECTROGRAPHS F_n 170 CMS.

The general details of construction of these instruments are exactly as described in conjunction with their quartz prototypes (E 383 etc.). Their optical systems are as described under E 52 above.

E 391.—All-Metal Spectrograph F_n 170 cms., as E 383, but with glass prism and lens in lieu of quartz.

E 401.—All-Metal Glass Spectrograph F_n 170 cms., as E 391 above, but with internal millimetre scale, including calibration curves.

(For other Glass Spectrographs, see pages E 6, E 15, and E 21 to E 25.)

MEDIUM SPECTROGRAPHS F_D 60 CMS.

(For Glass Spectrographs F_D 60 cms., see page E 15.)

(For a full description with enlarged spectra, see Hilger Publication No. 228.)

GENERAL SPECIFICATION

of Details common to Hilger F_D 60 cms. Quartz Spectrographs.

Dispersing System.—One Quartz Cornu Prism, angle 60° , 41 mm. high \times 65 mm. length of face. (Interchangeable glass trains can be fitted, see page E 14.)

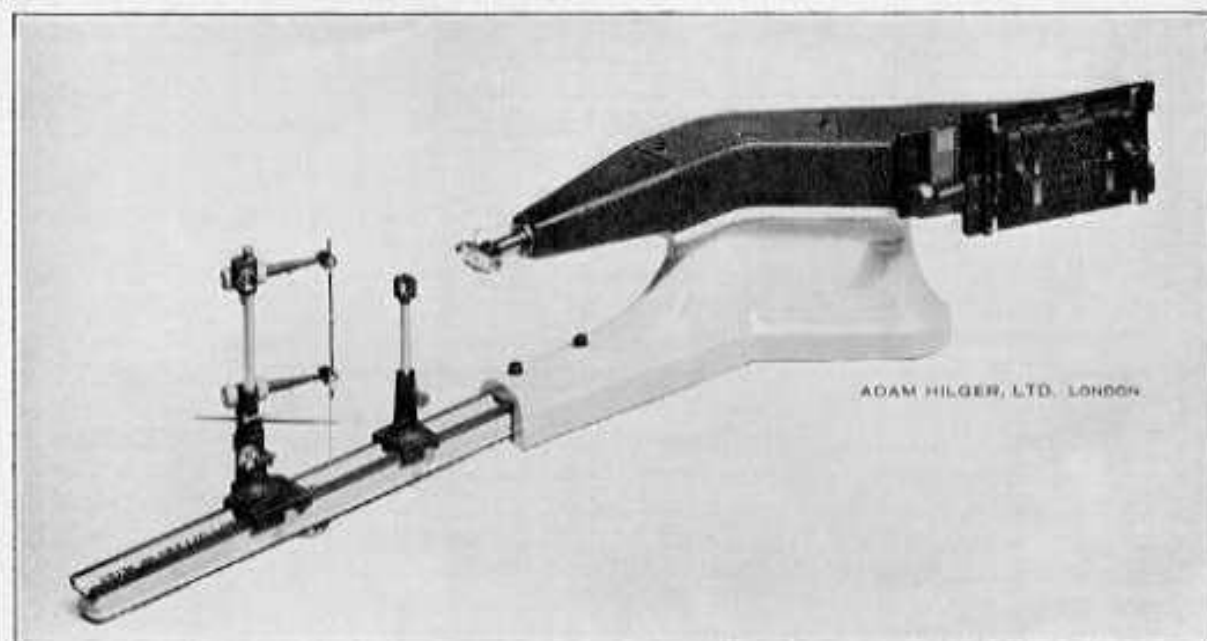

Fig. E 488/E 481/F 946/F 956

Lenses.—Quartz, 24 ins. (610 mm.) focus for D ; aperture 2 ins. (51 mm.). Figured by means of Hilger Interferometers.

Length of Spectrum from 2000 \AA to 10,000 \AA , 226 mm. (see page E 19 for details of dispersion).

Range of Spectrum.—2000 \AA to 10,000 \AA .

Size of Plate.—One plateholder is supplied taking 10×4 in. plates. Extra plateholders can be supplied to take plates 10×2 ins. or 9×24 cms. The E 488 Spectrograph can also be provided with a plateholder taking plates 10×2 ins. that can be bent to the full focal curve of instruments without breaking. The E 498 Spectrograph uses a flat plate. All metal plateholders are standard and interchangeable and extra ones can be supplied at any time.

Plateholder.—The method of attaching the plateholder to its movable chassis is one which avoids the use of slides and ensures a true metal-to-metal fit. A geared rack and pinion motion is provided for raising and lowering the plate. It has a click which operates at every 1 mm. movement of the plate, thus facilitating the rapid operation of the instrument especially for ultra-violet absorption spectrophotometry.

Slit.—Hilger type F 31, with stainless steel jaws, micrometer screw adjustment, reducing wedge and three aperture diaphragm, shutter behind slit jaws for exposure.

ADAM HILGER, Ltd., 98 Kings Road, Camden Road, London, N.W. 1

Wavelength or Wave-number Scale.—Spectrographs E 488 and E 498 are fitted with internal wavelength scales so mounted that they may be printed at will upon the photographic plate, and developed up at the same time as the spectra. In place of these scales, scales of wave-numbers can be substituted if desired.

Construction.—These Spectrographs are constructed entirely of metal.

The base of the E 498 and E 488 spectrographs is constructed to take a bar, 42 inches (107 cms.) in length, on which a number of accessories can be mounted. The length of the bar available for accessories is about 85 cms. The bar (actually it is an accurate optical bench) is of a special form which presents advantages, both of rigidity and accuracy of location of the accessories, over the triangular bar usually employed. It has been aged by heat treatment. A second, shorter bar, suitable for storing accessories not in use, can be supplied.

The special range of accessories for use with this bar is listed in *Hilger Catalogue F*.

Height to centre of instrument from bench 13 inches (33 cms.), from bar 10.1 inches (25.7 cms.).

BARFIT* FLAT-FIELD MEDIUM SPECTROGRAPHS (F_D 60 CMS.).

The following spectrographs have primarily been designed to avoid bending the photographic plate to suit a curved focal field. It is occasionally undesirable to bend the plate, particularly when specially coated plates, not readily obtainable on thin glass, are to be used. (It should be noted, however, that there is seldom any difficulty in obtaining plates that will safely bend to the curvature of the E 488, etc., instruments.)

So far as external details are concerned these spectrographs are almost identical with the standard medium quartz spectrograph E 488. The optical system, however, has been redesigned and the specially computed quartz objective produces an image field in which the residual curvature, hitherto quite appreciable, is reduced to a mere fraction of a millimetre. No sacrifice in definition has been permitted in arriving at this result, the optical performance being throughout of the same high quality as in the standard instruments.

E 498.—Barfit Flat-Field Medium Quartz Spectrograph (F_D 60 cms.) with internal wavelength scale and base to fit accessory bar.

For extra platcholders see page E 14.

* The word Barfit is registered as a Trade Mark in Great Britain and U.S.A.

BARFIT* STANDARD MEDIUM QUARTZ SPECTROGRAPHS †
F_v 60 CMS.

These instruments have many constructional improvements over earlier models.

In the lens construction used further improvements have resulted from the use of aspherical surfaces the production of which is controlled by means of the Hilger Interferometers (see Catalogue N). A higher standard of definition is attained for a larger aperture, this being accompanied nevertheless by a reduction in the number of component lenses; and it is found that these factors contribute together to produce a very material gain in photographic speed.

A notable increase in the richness of spectrum detail recorded has resulted from these improvements in the optical performance of the lens system. At full aperture an exposure of from 5 to 10 seconds is ample for metallic arcs of moderate intensity, while for such as the iron arc less than one second is sufficient.

Owing to the critical definition, increased apertures, and the greater range of spectrum, the system is naturally more sensitive than previous models (the former E 2 and E 3) to small focussing differences. The small residuals of curvature of image, although reduced, are nevertheless more noticeable than in models in which the spectrum was shorter: but the instrument is adjusted for the same range of spectrum as formerly, and a small focussing adjustment is provided to enable perfect focussing to be ensured, especially for the portion below 2100 Å when specially desired. Increased rigidity and accuracy are also demanded by the higher standard of definition, and are attained by the all-metal construction.

Full advantage of the speed of this instrument together with the other improvements mentioned above, with extension of the wavelength range to 10,000 Å, is attainable by use of the spectroscopic plates recently put on the market by Messrs. Kodak, Ltd., see Hilger Publication No. 179. With an hypersensitised III Q Xenocyanine plate the 10,140 Å line from a quartz mercury vapour lamp can be recorded in 2 minutes, while the 9300 Å line of Rb fed on to the pole of a copper arc taking 3.5 amps. is photographed with less than one minute exposure.

The accuracy with which wavelengths can be read on the wavelength scales fitted to E 488 is approximately as follows:

| Wavelength. | Error of Reading. | Wavelength. | Error of Reading. |
|-------------|-------------------|-------------|-------------------|
| 7000 Å | 100 Å | 2500 | 2 Å |
| 4000 | 20 | 2200 | 1 Å |
| 3000 | 5 | | |

Although in the plotting of absorption curves wavelengths are much more commonly employed than are wave-numbers, yet there are several notable advantages to be gained by the use of the latter. First, the formulae relating to spectral series, refractive index, dispersion, etc., have simpler forms when expressed in wave-numbers; secondly, absorption curves plotted with wave-numbers are usually found to have their interesting characteristics better distributed and, thirdly, the various instruments are more uniformly sensitive if graduated in wave-numbers than if in wavelengths. With a view to facilitating the study of absorption data in terms of a frequency scale the E 488 type of spectrograph can now be supplied fitted, if it is so desired, with a wave-number scale in place of a wavelength scale.

The plateholder is of an improved design which ensures not only that the whole photographic plate is held accurately to its proper curve, but also that short lengths of plate, used where only a limited spectrum range need be covered, are similarly held.

* The word Barfit is registered as a Trade Mark in Great Britain and U.S.A.

† A few of the earlier model Medium Quartz Spectrographs with mahogany cases (Catalogue Nos. E 2 and E 3) are still available.

- E 488.—Barfit Quartz Spectrograph F_D 60 cms. with base to take bar for accessories, with internal wavelength scale and one plateholder for 10×4 in. plates
- E 481.—Bar for Accessories—42 ins. long... ..
- E 482.—Short Bar—21 ins. long for carrying accessories not in use

EXTRA PLATEHOLDERS FOR MEDIUM SPECTROGRAPHS

When using spectrograph E 488 for research work in which the best definition is required simultaneously with the fullest aperture and without refocussing the use of the $10'' \times 2''$ plateholder (E 471) is recommended. With this an improved performance can be obtained in the region from 2000 Å to 3000 Å and especially from 2000 Å to 2300 Å.

E 470.—Extra Plateholder for Plates $10'' \times 4''$ for Spectrograph E 488 and Glass Spectrographs E 494, E 495 (see page E 15).

E 501.—Extra Plateholder for Plates $10'' \times 4''$ for Flat-Field Spectrograph E 498.

E 471.—Extra Plateholder for Plates $10'' \times 2''$ for Spectrographs E 488 and E 494, E 495 (see page E 15).

E 502.—Extra Plateholder for Plates $10'' \times 2''$ for Flat-Field Spectrograph E 498.

GLASS PRISMS AND LENSES FOR SPECTROGRAPHS F_D 60 CMS.

When increased dispersion in the visible region of the spectrum is desired, one of the following sets of glass lenses and prisms may be substituted at will for the quartz optical system of any of the foregoing medium quartz spectrographs F_D 60 cms. Each set consists of collimator and camera lenses in cells interchangeable with those holding the quartz lenses, and a prism of dense glass in a clamp mount, which is readily substituted for the quartz cornu prism without loss of adjustment, in a manner similar to that used in connection with E 383, page E 8. The spectrographs (E 488 and E 498) have a new and simple method of mounting the lens cells which permits their interchange without unscrewing the cells.

The spectrum is about 140 mm. long between 3700 Å and 8000 Å.

Wavelength scales cannot be supplied with these additional optical systems, but a complete spectrograph with both systems and scales for each can be—see E 496 below.

For Spectrograph E 498—

E 408.—Dense Glass Prism and Lenses to interchange with Quartz system of Flat-Field Barfit Quartz Spectrographs F_D 60 cms. E 497 and E 498. Length of spectrum between 3650 Å and 6560 Å approximately 130 mm. The set includes a $10'' \times 4''$ * plateholder giving the necessary slight curvature to the plate.

E 473.—Special Infra Red Glass Prism and Lenses to interchange with quartz system of E 497 or E 498, giving spectral range extended to 15,000 Å.

For Spectrograph E 488—

E 332.—Dense Glass Prism and Lenses to interchange with quartz system of all-metal quartz spectrographs F_D 60 cms. E 487, E 488.

* Or 9×24 cms., as desired.

GLASS SPECTROGRAPHS F_D 60 CMS.

Spectrographs similar to the foregoing can be supplied with the corresponding glass systems (E 332) only, *without* quartz lenses or prisms.

E 494.—Barfit Medium Glass Spectrograph F_D 60 cms., similar to Quartz Spectrograph E 487, but with glass prism and lenses in place of quartz.

E 495.—Barfit Medium Glass Spectrograph F_D 60 cms., similar to Quartz Spectrograph E 488, but with glass prism and lenses in place of quartz.

COMBINED INSTRUMENT

E 496.—Barfit Medium Glass and Quartz Spectrograph F_D 60 cms., similar to Quartz Spectrograph E 488, but with glass and quartz trains and wavelength scales for each, mounted internally.

INFRA-RED SPECTROGRAPH *

We make special glass spectrographs generally similar to the E 498 quartz spectrograph, but with a glass optical system so arranged as to take the spectrum from 4,000 to 15,000 Å.

| Wavelength | Length of Spectrum. | | Wavelength. | Length of Spectrum. | |
|-------------------|---------------------|---------|-----------------|---------------------|---------|
| | mm. | inches. | | mm. | inches. |
| 4,000 to 5,000 Å. | 76 | 3.00 | 4,000 to 8,000 | 143 | 5.65 |
| 4,000 to 6,000 | 110 | 4.35 | 4,000 to 14,000 | 176 | 6.95 |

E 526.—Barfit Infra-Red Glass Spectrograph with spectral range extending to 15,000 Å, *without* wavelength scale.

E 474.—Barfit Infra-Red Glass Spectrograph with spectral range extending to 15,000 Å, *with* internal wavelength scale.

(For separate optical system corresponding with the above for addition to Quartz Spectrograph E 498 see Catalogue number E 473 page E 14.)

PLATES.—The following special types of photographic plates, manufactured by Eastman Kodak Ltd. are of use in connection with the above spectrograph. See Hilger Publication No. 179 (post free on request). They are not stocked in Europe but can be obtained to order.

N Plates—sensitive from 7000 to 8000 Å

P and R Plates—sensitive from 7000 to 9000 Å

Q Plates—sensitive from 8000 to 11000 Å

Z Plates—sensitive from 8000 to 12000 Å

Photographs in the extreme infra-red at 15,000 Å can be obtained by the phospho-photographic method of Becquerel as used later by Prof. Lehmann. (*Ann. der Phys.*, 39, pp. 53-79, 1912.)

* For Infra-Red Spectrometers, see Catalogue D, and Hilger Publication No. 241.

INTERMEDIATE SPECTROGRAPH F_d 38 cms.

The Intermediate Quartz Spectrograph E 486 is intermediate in dispersion between the small and the medium quartz spectrographs, the three instruments having dispersions in the proportion 1 : 1.9 : 3.

SPECIFICATION

In permanent adjustment ; always ready for use.

Construction. All Metal.

Prism. Cornu, quartz, 60° angle, 38 mm. long face, 29 mm. high.

Focal length of camera, 38 cms.

Slit. Type F 758, with stainless steel jaws, screw adjustment, three aperture diaphragm and wedge diaphragm, shutter behind jaws.

Size of Plate. 5 ins. \times 7 ins. Plateholder has rack-and-pinion movement. Seventy or more spectra could be taken on one plate if desired. Where a part only of the spectrum is of interest, economy of photographic plates can be effected by using 5 in. long strips of plate.

Flat-Field.

Dispersion. 1980 A to 6000 A, 140 mm. approximately.

Range of Spectrum. 1980 A to beyond 8000 A.

Scale. Model E 486 is fitted with an internal wavelength scale which prints directly on the negative.

Bar. The accessory bar ensures accurate alignment of the spectrograph with its accessories and holds them rigidly.

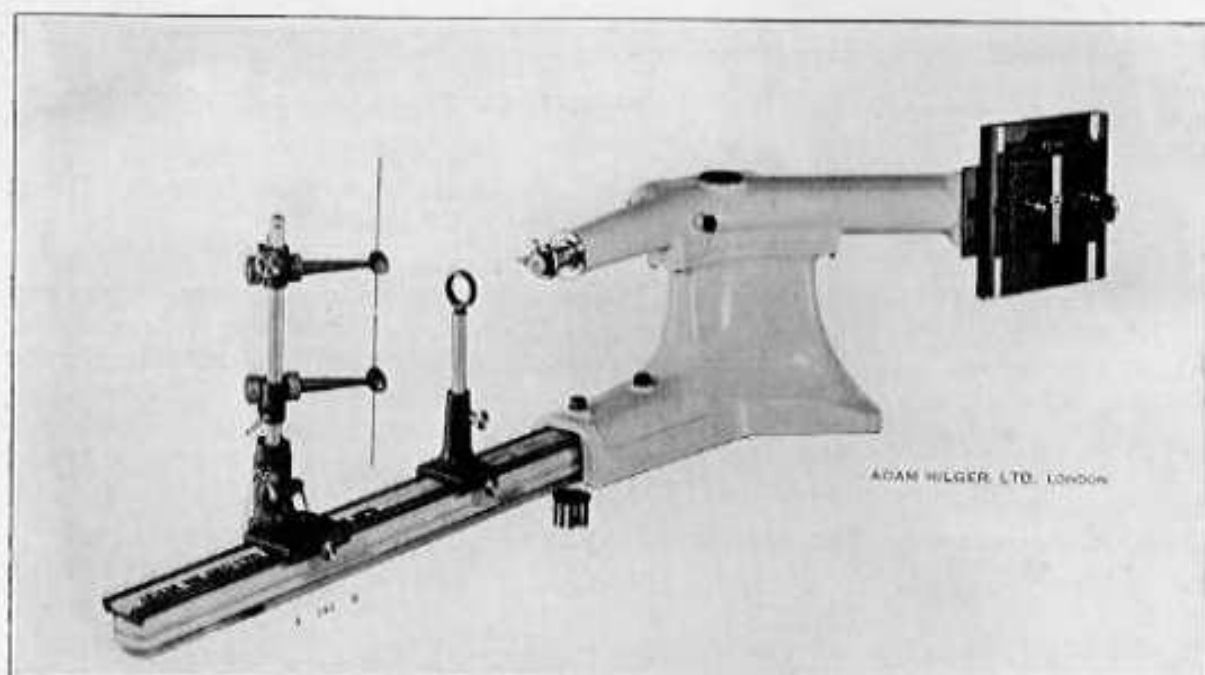

Fig. E 486—F 946—F 956—E 481

Intermediate Quartz Spectrograph with Accessory Bar, Gramont Arc and Spark Stand, and Condenser.

E 486.—Barfit Intermediate Quartz Spectrograph F_d 38 cms. fitted
with internal wavelength scale

E 481.—Bar for Accessories—42 ins. long

E 482.—Short Bar—21 ins. long for carrying accessories not in use

ADAM HILGER, Ltd., 98 Kings Road, Camden Road, London, N.W. 1

SMALL SPECTROGRAPHS F_b 20 CMS.

Fig. E 484—F 946—F 956—E 481

Small Quartz Spectrograph with Accessory Bar, Gramont Arc and Spark Stand, and Condenser.

SPECIFICATION

In permanent adjustment; always ready for use.

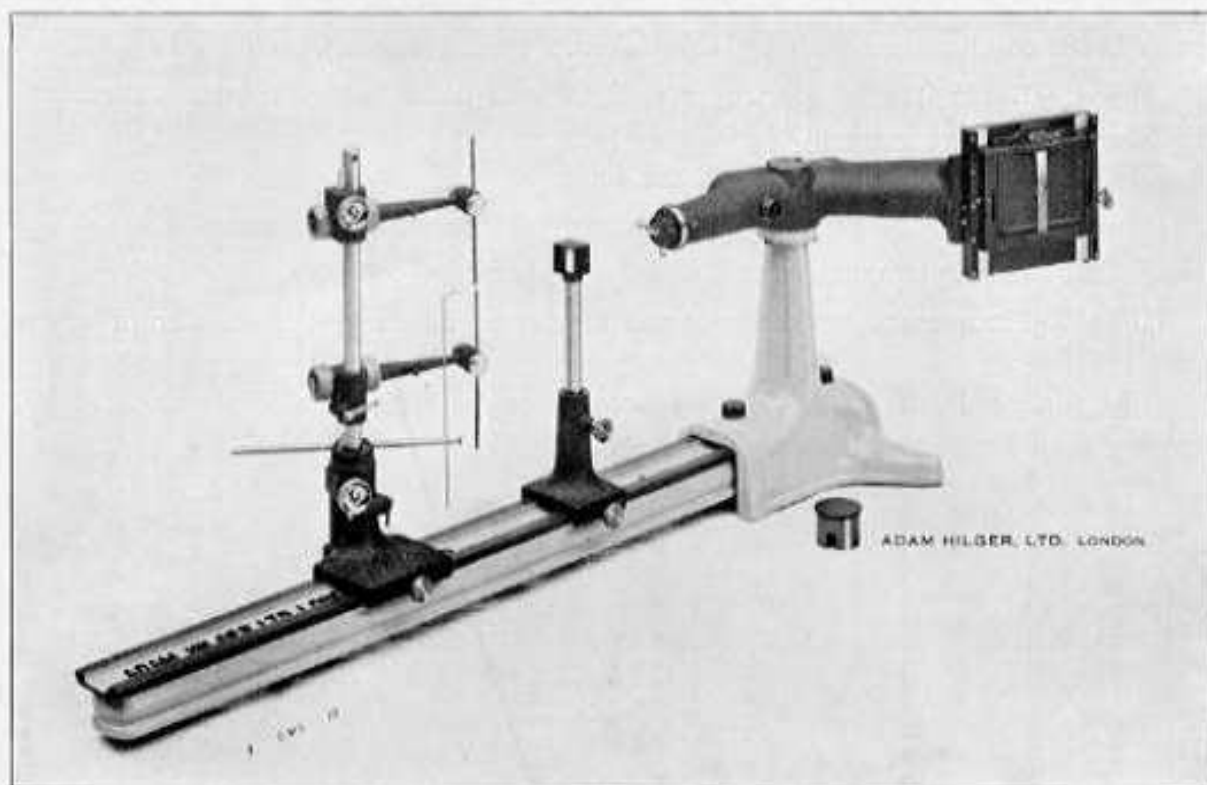
Construction. All Metal.

Prism. Cornu, quartz, 60° angle, 17 × 22 mm. face.

Collimator Lens. Focal length 208 mm. (8.2 ins.), diameter 19 mm. (0.75 ins.).

Camera Lens. Focal length 197 mm. (7.7 ins.), diameter 26 mm. (1.10 ins.).

Slit. Type F 758, with stainless steel jaws, screw adjustment, three aperture diaphragm and wedge diaphragm, shutter behind jaws.

Size of Plate. 4½ ins. × 3½ ins. (10.8 × 8.2 cm.). Plateholder has rack-and-pinion movement. Thirty or more spectra can be taken on one plate.

Flat-Field.

Range of Spectrum. 1850 Å to beyond 8000 Å. Length about 85 mm.

Scale. Model E 484 is fitted with an internal wavelength scale which prints directly on the negative.

Bar. Model E 484 has provision for the accessory bar that ensures accurate alignment of the spectrograph with its accessories and holds them rigidly.

ADAM HILGER, Ltd., 98 Kings Road, Camden Road, London, N.W. 1

Height to centre of instrument, from bench 13 ins. (33 cms.), from bar 10.1 ins. (25.7 cms.).

The spectrograph E 484 is mounted on a base of new design which can be rigidly attached to the Hilger Standard Accessory Bar identical with that used with spectrograph E 488 to align accessory apparatus (see Fig. E 484, etc.).

E 484.—Barfit Quartz Spectrograph F_{α} 20 cm. fitted with internal wavelength scale, on stand to fit accessory bar.

E 481.—Bar for Accessories—42 ins. long

E 482.—Short Bar—21 ins. long for carrying accessories not in use.

E 472.—Extra plateholder for E 484 Spectrograph, $4\frac{1}{2} \times 3\frac{1}{2}$ ins.

E 440.—Fluorescent Screen in metal mount to fit dark slide holder of above spectrograph.

For further details of E 484 with accessories see Hilger Publications Nos. 107 and 156.

FOR GUIDANCE IN THE CHOICE OF APPARATUS

SEE

“SPECTROGRAPHIC OUTFITS *for* METALLURGICAL ANALYSIS”

and

“OUTFITS *for* ABSORPTION SPECTROPHOTOMETRY.”

POST FREE ON REQUEST

APPROXIMATE LENGTHS OF SPECTRA GIVEN BY SOME HILGER
SPECTROGRAPHS

(MEASURED ON THE PLATE IN CMS. FROM WAVELENGTH 8,000)

(See also the *Interchangeable Spectrographs* on page E 35.)

| Type of Spectrograph. | Wavelength in Angstroms. | | | | | | |
|---|--------------------------|-------|-------|-------|-------|-------|-------|
| | 8,000 | 5,000 | 4,000 | 3,500 | 3,000 | 2,500 | 2,000 |
| Quartz F _n 170 cms., E 492, E 384, E 383, E 374, E 1, etc. (see pages E 2-10). | 0 | 5.6 | 11.4 | 16.3 | 24.6 | 38.9 | 67.0 |
| Glass F _n 170 cms., E 478, E 391, E 56, E 52, etc. (see pages E 6 and E 10). | 0 | 15.2 | 31.5 | — | — | — | — |
| Quartz F _n 60 cms., E 498, E 488 (see pages E 11-14). | 0 | 2.3 | 4.3 | 5.9 | 8.5 | 13.0 | 22.2 |
| Glass F _n 60 cms., E 496, E 495, E 494, E 408, E 332, etc. p. 15. | 0 | 5.6 | 10.9 | 16.3 | — | — | — |
| Quartz F _n 38 cms., E 486 (see page E 16). | 0 | 1.5 | 2.9 | 4.0 | 5.7 | 8.5 | 14.3 |
| Quartz F _n 20 cms., E 484 (see pages E 17-18). | 0 | 0.8 | 1.5 | 2.1 | 3.0 | 4.5 | 7.5 |
| Glass E 328 (see page E 23). | 0 | 3.1 | 6.4 | — | — | — | — |
| Glass E 349 (see page E 22). | 0 | 7.6 | 16.1 | — | — | — | — |
| Glass E 518 (see page E 21). | 0 | 1.6 | 3.3 | — | — | — | — |
| Quartz E 517 (see page E 21). | 0 | 0.8 | 1.4 | 1.9 | 2.8 | 4.2 | 6.7 |

LARGE APERTURE SPECTROGRAPHS

F/4 SPECTROGRAPHS

For the Photography of Spectra of very low brightness such as the Raman Effect

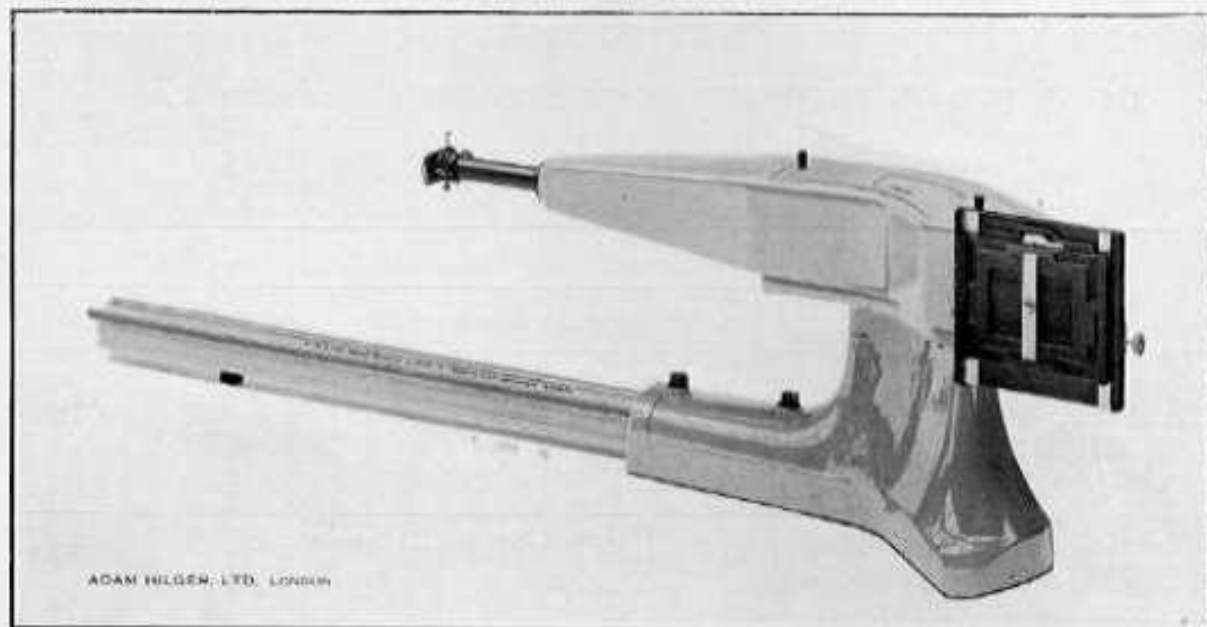

Fig. E 517/E 481

The design of a spectrograph of considerable light-gathering power for use in connection with such work as that of the Raman Effect is controlled by a number of considerations. It is, of course, desired that the loss of light within the instrument shall be reduced as much as possible, and as these losses are attributable to absorption and reflection the less the number of optical parts the better the performance is likely to be. On this account, therefore, the instrument embodies only one prism.

Further, in order that the camera should give a brilliant image it has been given an aperture ratio of F/4. Spectrographs of larger aperture ratios can be supplied, see for instance the Night Sky Spectrograph E 424 (F/1), and the D 96 (F/1.8); the aperture ratio F/4 has been chosen as affording a suitable compromise between light intensity and dispersion for the kind of investigation in question. Where, as in the Raman Effect, the radiation comes from a region sufficiently extensive to use a long slit, no advantage is gained by having a collimator also of large aperture ratio, since for a given size of spectrum line as recorded on the photographic plate both the length and width of the slit can be made proportionately greater to compensate for the increased length of collimator. Moreover, the Raman Effect is best produced in a long tube or cylindrical specimen, and hence a collimator of large aperture ratio could not be effectively employed. For these reasons the collimator has been made relatively long (F/10).

The design of the spectrograph is based upon that of our well-known E 488 Quartz Spectrograph, the collimator and prism being identical with those of that instrument (collimator lens 61 cms. focal length, 5.1 cms. diameter; prism 41 mm. high \times 65 mm. long face). The camera lens, however, is of a shorter focal length (20.6 cms. for 0.254μ) having a large focal aperture (F/4). The plateholder takes standard quarter-plates ($4\frac{1}{4}$ ins. \times $3\frac{1}{4}$ ins.).

ADAM HILGER, Ltd., 98 Kings Road, Camden Road, London, N.W. 1

The design of the camera lens system itself is based upon that worked out for our large aperture F/1.8 monochromatic illuminator (Catalogue Number D 96), but in this case the separation of the component lenses is invariable. Although the ends of the spectrum are out of focus, a range of spectrum, more than sufficient for investigation of the Raman Effect excited by any ultra-violet line, can be obtained in sharp focus at one time, and a slight adjustment of focus will bring any other desired part into good definition.

As an example of the use of this instrument we may instance the following. Using a cylindrical quartz specimen illuminated by a mercury vapour lamp over an effective length along the axis of only 1 cm., the Raman Effect produced by the 3130A group of the mercury arc spectrum was photographed on an Ilford Auto-Filter plate with an exposure of 15 minutes.

The instrument is entirely constructed of metal and has a base which fits the standard Hilger Accessory Bar. The slit is our F 31. A rack and pinion adjustment to the plateholder enables several spectra to be taken on the one plate.

See page E 19 for dispersion.

E 517.—Barfit Large Aperture Quartz Spectrograph, F/4, as described above.

F/4 GLASS SPECTROGRAPH

This instrument is similar in general arrangement to the Quartz F/4 Spectrograph already described above, but in place of quartz optical components it has lenses of glass and a compound dispersing prism of the Rutherford type.

See page E 19 for dispersion.

E 518.—Barfit Large Aperture Glass Spectrograph, F/4.

For other Large Aperture Spectrographs, see below and pages E 22-25.

ADDITIONAL OPTICAL SYSTEMS for above Spectrographs

E 442.—Quartz Lenses and Prism for E 518 All-Metal Large Aperture Glass Spectrograph, F/4.

E 443.—Glass Lenses and Prism for E 517 All-Metal Large Aperture Quartz Spectrograph, F/4.

F/2 QUARTZ AND GLASS SPECTROGRAPHS

The all-metal spectrographs above described of relative aperture F/4 may also be supplied with suitable modifications and additions converting them to F/2 spectrographs. Instruments conforming to the above descriptions may also for a small extra charge be made capable of subsequent conversion to F/2 spectrographs if notice is given when placing the order that this is desired. The additions include a highly corrected F/2 camera objective of quartz or glass and a suitable camera for use therewith. The complete F/2 spectrographs are listed as follows:

E 505.—Large Aperture Quartz Spectrograph, F/2.

E 506.—Large Aperture Glass Spectrograph, F/2.

We shall be pleased to quote on request for the separate optical systems to convert from an F/4 to an F/2 spectrograph of this type.

QUARTZ SPECTROGRAPHS OF LARGER APERTURE

Quartz Spectrographs of larger aperture ratios can be quoted for, or Quartz Spectrographs of the same proportional dimensions as the above, but of larger sizes, the limit to the size of such spectrographs being imposed by the size of quartz prism for which we have material available. At the present time quartz prisms up to 150 mm. height \times 200 mm. length of face can be supplied from material in stock.

The F/1.8 Quartz Monochromatic Illuminator and Spectrograph referred to above is fully described in Catalogue D, and in a separate pamphlet (sent post free on request).

ADAM HILGER, Ltd., 98 Kings Road, Camden Road, London, N.W. 1

LARGE GLASS PRISM SPECTROGRAPH OF LITTROW FORM

Aperture Ratio F/7

High dispersion when required in prism spectrographs of ordinary size is usually accompanied by low relative aperture owing to the need for increasing the focal length of the camera objective. This prevents the instrument from being used for

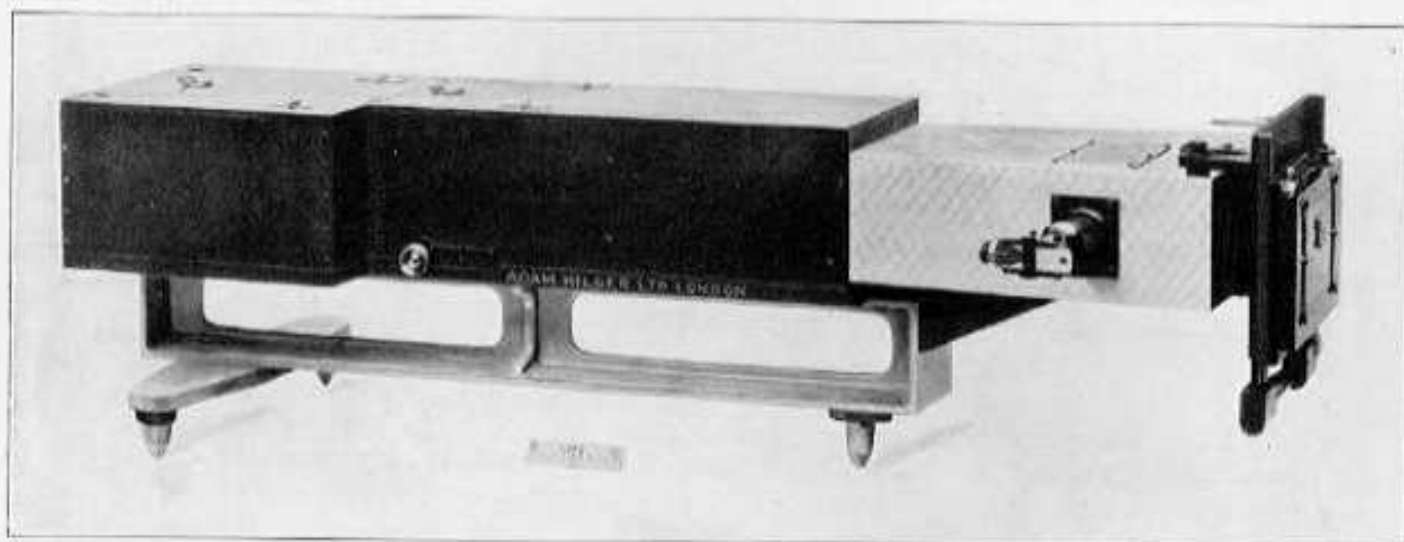

Fig. E 349

some important kinds of work such as the investigation of the fainter sources of light, as the instrument would be too insensitive. In the spectrograph E 349, by appropriate design and by the employment of optical work of suitable size and correction, we have been able to obtain a high dispersion, i.e. 11 Å/mm at 4359 Å combined with a relative aperture F/7 which for this dispersion must be considered great.

The Littrow form was adopted on account of the advantages gained from this type of construction. The space occupied by the instrument is relatively small and the construction is extremely rigid.

The camera objective is very highly corrected and first quality definition is obtained. Astigmatism, which is generally very considerable in spectrograph systems, is reduced in this instrument to a negligible amount, so that the instrument is very suitable for being used in conjunction with high resolving power apparatus.

The whole spectrum from 37μ to the near infra-red is obtained in sharp focus in one exposure on a 10 ins. \times 4 ins. plate, the tilt of the plate being very small.

The prism system consists of one 60° and one 30° prism, being the equivalent in dispersion of three 60° prisms, of dense flint glass each of 15.2 cms. face and 11.7 cms. high (6 \times 4.6 inches).

The prism system is however fitted with automatic adjustment so that any desired wavelength region within the range of the instrument may be photographed approximately under conditions of minimum deviation at full aperture and in critical definition.

The camera objective is of diameter 5 inches (127 mm.), relative aperture F/7.

The spectrum is 9 inches (23 cms.) long and extends from 3850 to 8000 Å.

The dark slide is provided with vertical adjustment enabling a number of exposures to be taken on one plate.

The slit is the standard F 31 model.

The complete instrument is mounted on a cast iron girder of massive design.

E 349.—F/7 Glass Littrow Spectrograph.

LARGE APERTURE TWO-PRISM GLASS SPECTROGRAPH

Aperture Ratio F/5.7

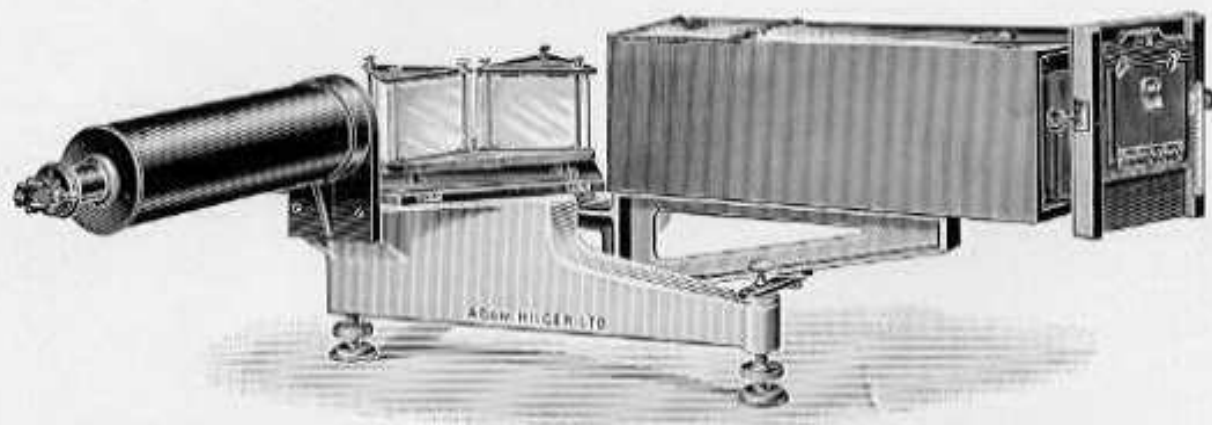

Fig. E 328

(Prism Cover not shown.)

The prism system consists of two 55° prisms of dense flint glass.

The collimator objective is of aperture 88 mm. (3.5 inches).

The camera objective is of aperture 112 mm. (4.4 inches) focal length 508 mm. (20 inches), relative aperture F/5.7. It is corrected for coma and curvature of field, the spherical aberration of the whole system being corrected for the whole range of spectrum photographed.

The spectrum, extending from 3800 Å to 8000 Å, is photographed on a plate, $4\frac{1}{4}$ ins. \times $3\frac{1}{4}$ ins., and is about 4 inches (100 mm.) in length.

The slit is the standard F 31 model (not the F 24 shown in the figure).

The dark slide is provided with a vertical rack motion, enabling a number of exposures to be made on one plate.

The camera is so arranged that it may be rotated to bring the collimator and camera on one axis, so that the instrument may, by removing the prisms, be used for other purposes. The instrument in use is totally enclosed; in the figure the section of the casing covering the prisms has been removed to show the latter.

See page E 19 for dispersion.

E 328.—Large Aperture Two-Prism Glass Spectrograph.

F/1.5 TWO-PRISM GLASS SPECTROGRAPH F₀ 13 CMS.

Fig. E 523

This instrument is generally similar in design to our spectrograph E 328 but differs from this instrument as follows :

The prism system consists of two prisms of dense flint glass of high dispersion, the angle of each being 63° .

The collimator objective is of aperture 88 mm.

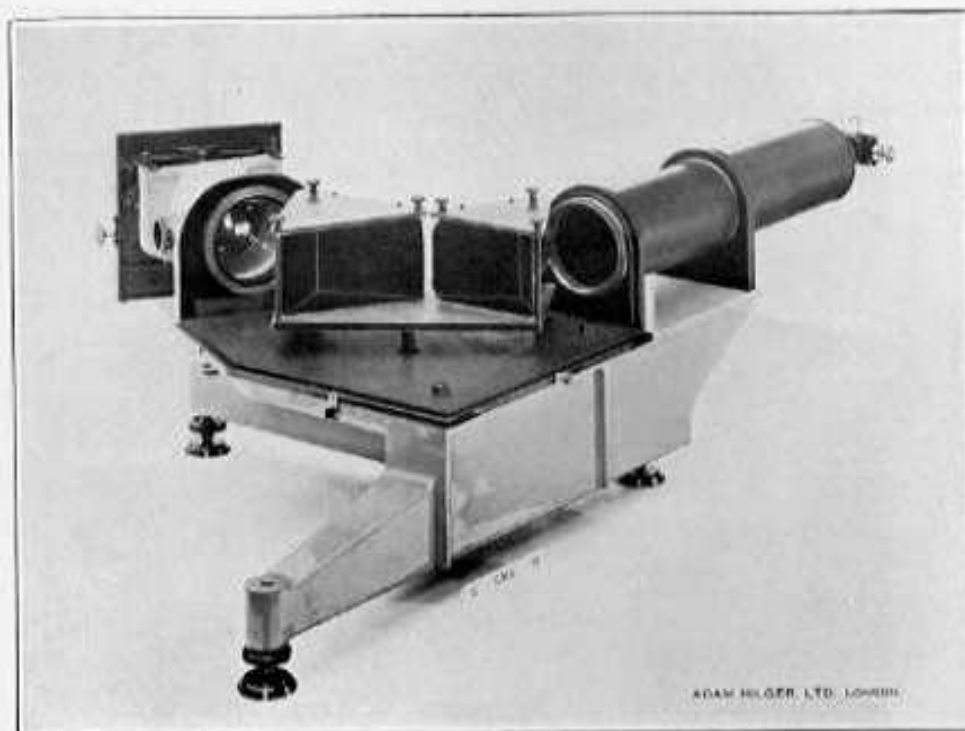
The camera objective is of relative aperture F/1.5, focal length 132 mm. It has been especially computed and has all necessary corrections including corrections for axial and extra-axial aberrations, for flatness of field and for the chromatic variations of the aberrations.

The camera is fixed and is provided with an all-metal body to which the objective is fitted. It is mounted on a rigid casting which is bolted to the main bed of the spectrograph.

The dark slide for the camera body is of a special new design, of light and rigid construction and the tilt of focal plane is very small.

The collimator slit is our standard F 31 model. The spectrum length from wavelength 7000 Å to 3700 Å is approximately 37 mm. (57 Å/mm. at W.L. 4358 Å.)

The above spectrograph has been especially designed for use on faint or transient light sources, for investigations on the Raman Effect and for similar cases where extreme rapidity is required. For comparison it may be stated that exposures of the order of about 0.01 second suffice for a light source such as an iron arc consuming 3.5 amps. Exceptionally sharp definition is obtained and the instrument can be recommended for all cases of technical investigation and research combining the needs for a high standard of definition and extreme rapidity.

E 523.—F/1.5 Two-Prism Glass Spectrograph.

ADAM HILGER, Ltd., 98 Kings Road, Camden Road, London, N.W. 1

EXTRA LARGE APERTURE GLASS SPECTROGRAPH

THE NIGHT-SKY SPECTROGRAPH

Aperture Ratio F/1

This Spectrograph has been specially designed for the examination of light sources of very low intensity, such as the light from the Night Sky (*see J. C. McLennan and H. J. C. Ireton, Proc. Roy. Soc., A 129, 1930*). It has one 60° prism of light flint glass, 85 × 52 mm. height of face, and an achromatic collimator objective of 50 mm. diameter and 560 mm. focal length. The slit is our F 31 mounted in a rack and pinion focussing tube.

Either of two camera lenses can be fitted. A Ross four-component lens covering the greater part of the spectrum at F/1, or a single lens with aspherical surfaces controlled by means of the Hilger Interferometers, and only corrected for the immediate neighbourhood of 5461 Å. The advantage of the Hilger lens is its greater economy of light, since it has but two surfaces compared to the eight of the Ross lens. Both lenses have a focal length of 50 mm.

The metal plateholder takes plates $2\frac{5}{8}$ ins. × $1\frac{3}{4}$ ins. (4.5 × 6 cms.).

E 424.—Large Aperture F/1 Glass Spectrograph fitted with Ross Lens.

E 426.—Large Aperture F/1 Glass Spectrograph fitted with Hilger Aspherical Lens.

E 429.—Simple Trestle Support for photography of the Night Sky, etc.

E 430.—Tripod Stand holding the instrument horizontally.

E 431.—Ross F/1 Compound Lens fitted to E 426 in addition to Hilger lens.

Eastman Plates of the type G are suitable for use with this Spectrograph (*see Hilger Publication No. 179*).

(For another Large Aperture Glass Spectrograph (F/4) *see page E 21*.)

COMPOUND DIRECT VISION LIQUID DISPERSOR

The Compound Liquid Dispersor has been designed with the object of attaining a high dispersion suitable for investigations of the Raman Effect. It consists of a substantial metal tubular mounting containing two cylindrical glass prisms of 50 mm. aperture having perpendicular outer end faces and forming by their inner faces the walls to a liquid prism of high angle, as shown in Fig. E 522. The glass prisms are enclosed by plane parallel windows which are clamped to the approximately parallel, accurately ground, ends of the metal mounting. The liquid chamber is provided with a tubular overflow reservoir, situated parallel to the axis of the prisms, to provide space for the thermal expansion and contraction of the liquid. The liquid prism component is thus maintained full at all temperatures.

A suitable liquid for use in the Dispersor is ethyl cinnamate. With a camera lens of focal length 550 mm., ethyl cinnamate enables a dispersion of 0.062 mm/Å (16Å/mm.) to be obtained in the neighbourhood of 4360 Å. For this wavelength the Dispersor transmits without deviation at average room temperature (20° C.) Two such prisms may thus be used in train by being placed end to end on any convenient mounting, having for example the form of a simple optical bench, and so provide a dispersion of 8Å/mm. with a camera lens of focal length 550 mm. For this focal length the spectrum from 3900 Å to 5500 Å approximately fills a quarter plate with one prism while for two prisms this size of plate covers the wavelength range 4080 Å to 4770 Å.

ADAM HILGER, Ltd., 98 Kings Road, Camden Road, London, N.W. 1

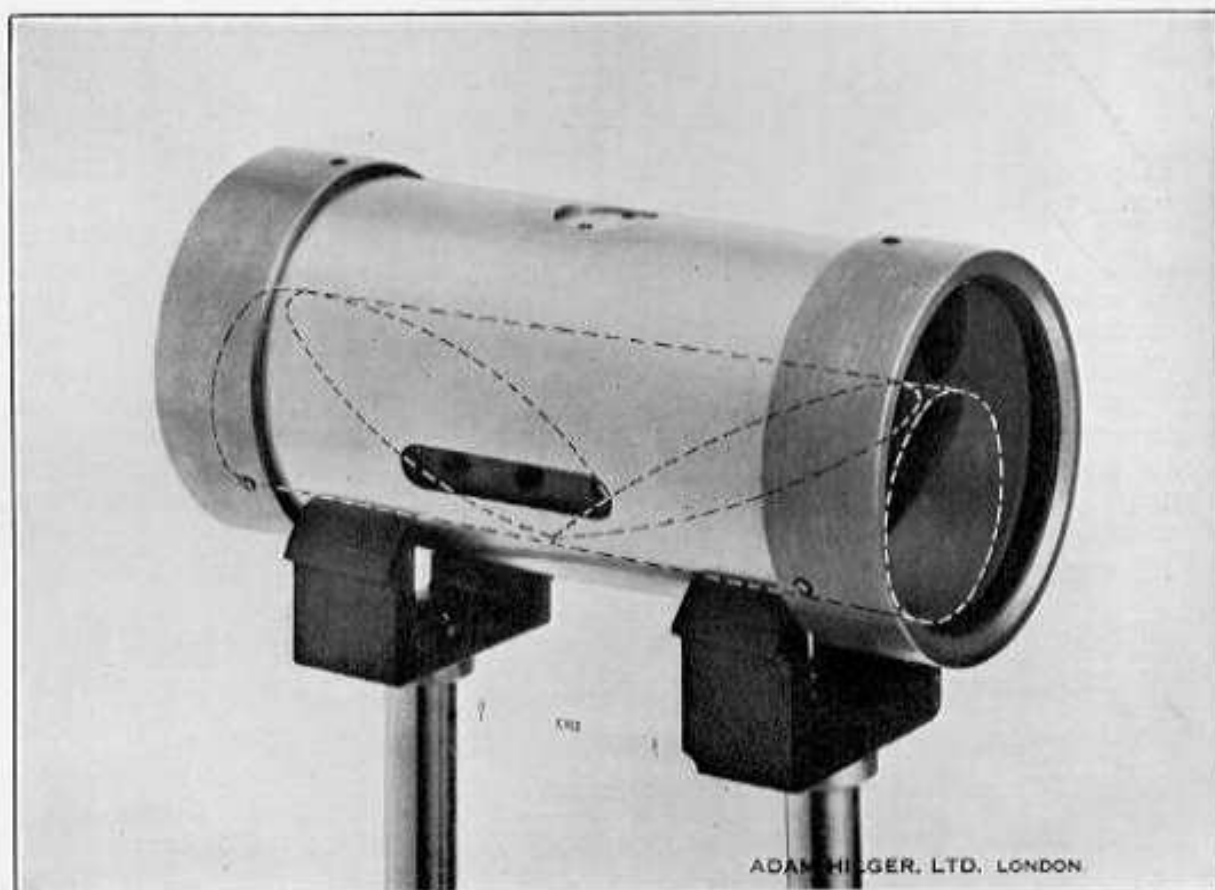

Fig. E 522

Fig. E 522a shows graphically the linear dispersion with one prism and a focal length of 550 mm., assuming the focal plane to be perpendicular to the optical axis. This figure also includes a graph of the local linear dispersion in Angstroms per millimetre.

This dispersing system is found on actual test to give very good definition and has the advantage of marked freedom from thermal heterogeneity resulting from the considerable mass of metal forming the mounting. A further advantage of this dispersor when used for the Raman Effect is the almost complete absence of polarisation in the dispersed light. When exposures of less than one hour are possible, rigid temperature control is not necessary, provided the temperature gradient of the laboratory can be kept within narrow limits about the time of the exposure, but for very long exposures provision should be made for controlling the temperature, preferably to an accuracy of $\pm 0.01^\circ \text{C}$, during the exposure. In a laboratory having apparatus for temperature control to $\pm 0.01^\circ \text{C}$ sharp definition has been obtained after an exposure of four hours.

The nature of the dispersive liquid to be used in such a prism requires careful consideration as some otherwise apparently suitable liquids such as carbon bisulphide are known to decompose under the action of light and to develop strong light-scattering properties. Ethyl cinnamate is free from these undesirable properties and has been found very suitable for use for this purpose.

E 522.—Compound Direct Vision Liquid Dispersion, complete in
tubular mount, without liquid

ADAM HILGER, Ltd., 98 Kings Road, Camden Road, London, N.W. 1

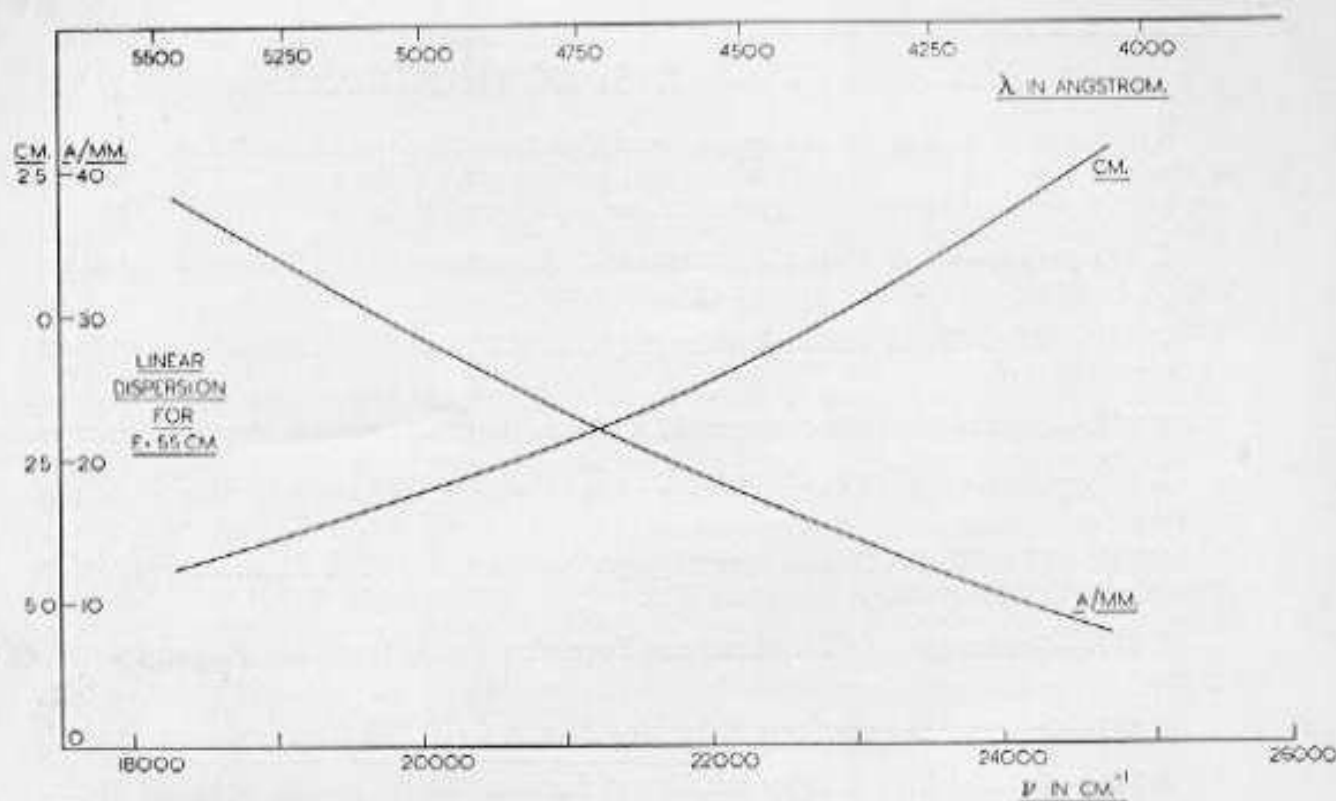

Fig. E 522 A

ADAM HILGER LTD. LONDON.

LITTROW SPECTROGRAPH OF HIGH DISPERSION

(As supplied to the Commonwealth Solar Observatory, Canberra, Australia)

This Littrow type spectrograph has a prism system consisting of two 60° prisms and one 30° prism of dense flint glass. The height of the prisms is 10 cms. (4 inches) and the length of their faces 15 cms. (6 inches). The achromatic lens is 11.4 cms. in diameter, and has a focal length of 25 feet.

The dispersion at 5000 Å is approximately 1 Å per mm., and at 4300 Å it is nearly 0.5 Å per mm.

The instrument is designed to be built into a brick or other tunnel or chamber where access to the prisms and lens would be difficult and undesirable, since notable sources of bad definition in such large spectrographs are the variations of temperature and pressure that may occur in the body of the instrument. The positions of the optical parts are therefore controlled externally; electric motors actuating adjustments whose indicators (or scales) can be observed by means of a telescope attached to the dark slide mounting. The whole optical system is mounted on a carriage which can be moved transversely to the axis of the instrument, thus permitting the introduction of an alternative optical system if desired.

The dark slide mounting is a massive iron casting designed to be built into an end wall of the chamber, after the manner of a window frame. The plateholder can be tilted about a vertical axis, either side of normal. In the case of the glass train a maximum of 45° of tilt is allowed for.

The size of plate used is 10 ins. \times 4 ins. (or, if desired, the instrument can be adapted to take plates 9 \times 24 cms.). A rack and pinion motion raises or lowers the plate to permit of several exposures on the one plate.

The slit is our F 31 (see page F 6) with reducing and three aperture diaphragms.

E 347.—25 ft. Littrow Spectrograph with Glass Optical System.

E 348.—25 ft. Littrow Spectrograph with Quartz Optical System.

ADAM HILGER, Ltd., 98 Kings Road, Camden Road, London, N.W. 1

ASTRONOMICAL SPECTROGRAPHS

The range of Hilger Spectrographs and Spectroscopes for astronomical purposes is now described in Catalogue G where full particulars will be found. The following is a brief résumé of their catalogue numbers and descriptions.

E 329.—Ultra-Violet Stellar Spectrograph. Aperture $F/5$. Range of spectrum 3000 Å to 8000 Å. Two 60° prisms of U.V. glass.

E 337.—Ultra-Violet Stellar Spectrograph, as E 329, on tripod stand but without following telescope.

E 338.—Quartz Stellar Spectrograph, without stand but with following telescope.

E 339.—Quartz Stellar Spectrograph, as E 338, with stand but without following telescope.

E 340.—Ultra-Violet Stellar Spectrograph (as made for J. S. Plaskett, Dominion Astrophysical Observatory) Aperture $F/5$.

E 341.—Condenser (of U.V. Glass) and Focussing Mount for E 340 Stellar Spectrograph.

E 343.—Quartz Condenser and Focussing Mount for E 340 Stellar Spectrograph.

E 344.—Neutral Tint Wedge and Mount for attachment to slit of E 340 Stellar Spectrograph.

E 345.—Stellar Spectrograph with Single Glass Prism and $F/4$ camera.

E 346.—Stellar Spectrograph with Quartz Optical System and $F/4$ camera.

E 359.— $F/12$ Camera for E 345 Stellar Spectrograph.

E 360.— $F/12$ Camera for E 346 Stellar Spectrograph.

LARGE SPECTROGRAPHS OF STANDARDISED DESIGN WITH INTERCHANGEABLE OPTICAL SYSTEMS

INTRODUCTION

Spectroscopic researches have in recent years tended more and more to require spectrographs whose optical systems are chosen with special reference to each research. Sometimes the ultra-violet spectrum is required, sometimes the visible alone; a prism system will best suit one problem, a grating another. A spectrograph designed for each research is expensive to construct, requires long to make, and when that particular research is completed it is not always applicable to the next set of experiments. These difficulties are accentuated when it is necessary to employ two or more optical systems to obtain all the data required. A consideration of the whole question of large spectrographs undertaken by us some few years ago convinced us that there was no difficulty in so designing the mechanical parts of a spectrograph that it should be appropriate to every requirement shown by experience as likely to arise. We have, as a result of these investigations, replaced a number of the special models of large spectrographs by a series of instruments in which the basis mechanical parts are the same, but in which a variety of optical systems can be applied with equal convenience and efficiency. These instruments have been designed with very great care and embody all the features which our experience with large spectrographs has shown to be desirable.

Two Models

The instruments are made in two models, which are described below:

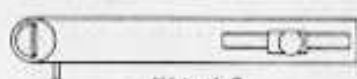

Fig. A 2

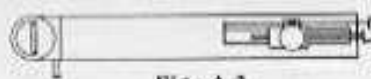

Fig. A 3

Hand Adjusted Model (Fig. A 2.)—Completely enclosed in wood case with hand operated adjustments. Plate size 10 ins. \times 4 ins. in all sizes.

Screw Adjusted Model (Fig. A 3.)—Exactly similar to the hand adjusted models, but with focussing and rotating table both operated by screw motions from outside the wood case, the various scales being read through a glass window.

Five Optical Systems

Either model consists of a girder base on which is mounted a camera and a focussing carriage with rotating table. The carriage and table will take any of the following Optical Systems (see Fig. B).

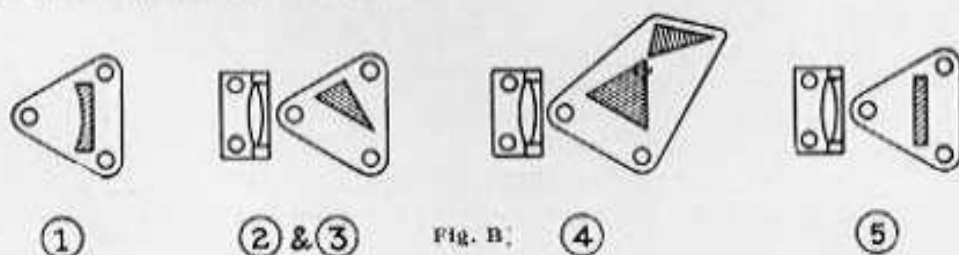

- (1) Eagle Mounting Concave Grating.
- (2) Littrow Mounting with Quartz Prism and Lens.*
- (3) " " " " One Glass Prism and Lens.
- (4) " " " " One 30° and one 60° Glass Prism and Achromatic Lens.
- (5) " " " " Plane Grating and Achromatic Lens.

* The application of the "Littrow" arrangement of prisms was described in a paper by O. von Littrow, *Ueber eine neue Einrichtung des Spectralapparates*, *Wien. Ber.* 47, 11, page 26-32, 1863, although the principle was first actually used by Dubosecq.

All optical systems are strictly interchangeable. If an instrument is purchased with one system, any other may be added later if desired, thus avoiding the cost of special adaptation or a new instrument.

Customers who have their own grating or other optical parts of suitable size may purchase the instrument alone, and may usually have them adapted to our standard mounts at comparatively low cost.

Three Sizes

Either model is made up in three sizes with focal lengths of approximately 100, 150 and 300 cms., thus giving a good range of dispersion from which a selection may be made according to the work for which the instrument is required.

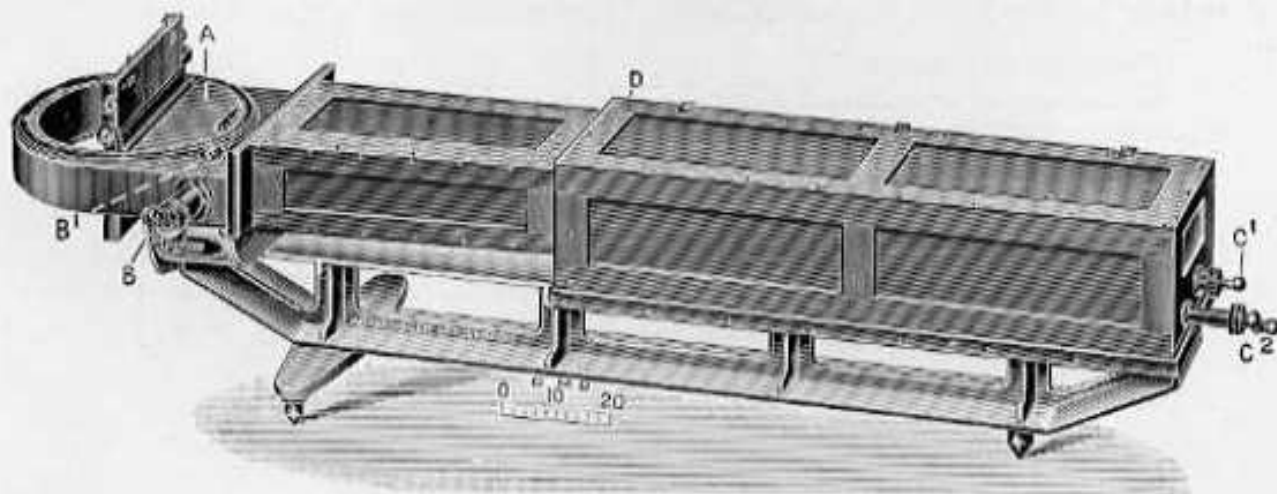

Fig. C

DESCRIPTIONS OF THE FEATURES DISTINGUISHING THE TWO MODELS

Hand Adjusted Model.—In this model the focussing carriage moves on a cast iron slide and has a slow motion for setting its position by a scale and vernier reading to 1/10 mm. The case has a large door in the side to enable this to be done.

The carriage has a revolving table on which the various dispersing systems can be placed. The table, which is rotated by a worm wheel, the driving handle of which extends outside the case, is engraved with a degree scale and reads to three minutes by a drum on the worm spindle mounted outside the case so that the divisions are easily read.



COMPLETE INSTRUMENT

A = camera, B = slit, B' = mount for reflecting prism, C¹, C² = adjusting handles with divided drums, D = wood casing.

The camera is entirely constructed in metal (with the exception of the dark slide) and consists of a large ring casting, in the centre of which the plateholder is mounted.

ADAM HILGER, Ltd., 98 Kings Road, Camden Road, London, N.W. 1

The rotation of the plate is set by a circle 15 inches in diameter divided in degrees and reading to $1/10^\circ$ by vernier. The dark slide is provided with rack and pinion vertical motion. An adjustable diaphragm which limits the width of the spectrum is provided with rack and pinion vertical adjustment so that several photographs can be taken in juxtaposition when using the concave grating. The position of the diaphragm is indicated by a millimetre scale. The slit is mounted at the side of the camera

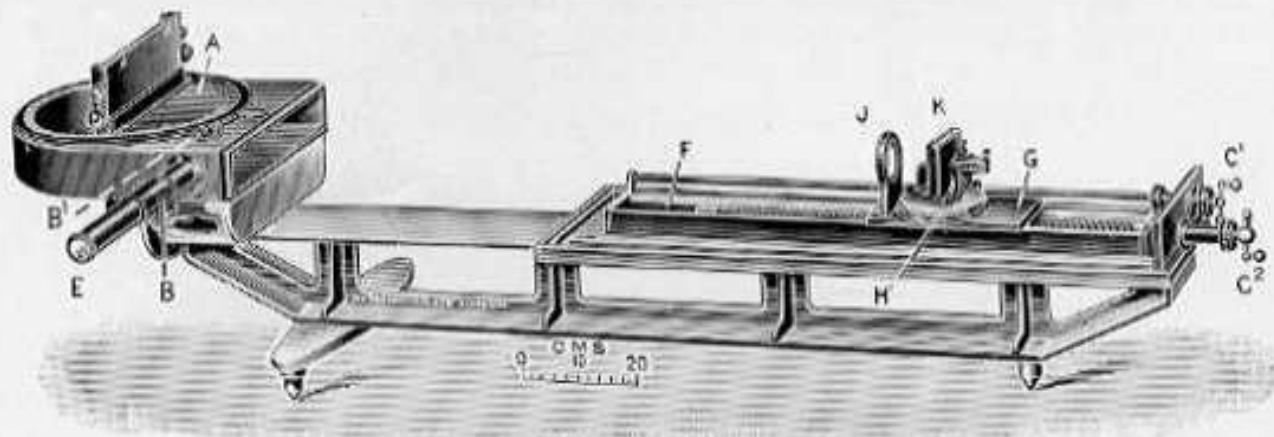

INSTRUMENT WITH CASING REMOVED

A = camera, B = slit, B' = mount for reflecting prism, C¹, C² = adjusting handles with divided drums, E = condenser mount on slit, F = slide, G = carriage for optical parts, K = plane grating and mount E 251, J = achromatic lens and mount E 260, H = divided circle operated by C¹.

in the same horizontal plane as the optical system and plate, light being reflected by a right-angled prism mounted near the end of the plate. In the 100 cm. and 150 cm. sizes it is necessary to move this prism to one position for use with the single prism systems and to another for use with the concave grating and achromatic systems. It is so mounted that it can quickly be changed as required. In the 300 cm. size the right-angled prism is fixed in one position for all models. In all cases the slit remains fixed.

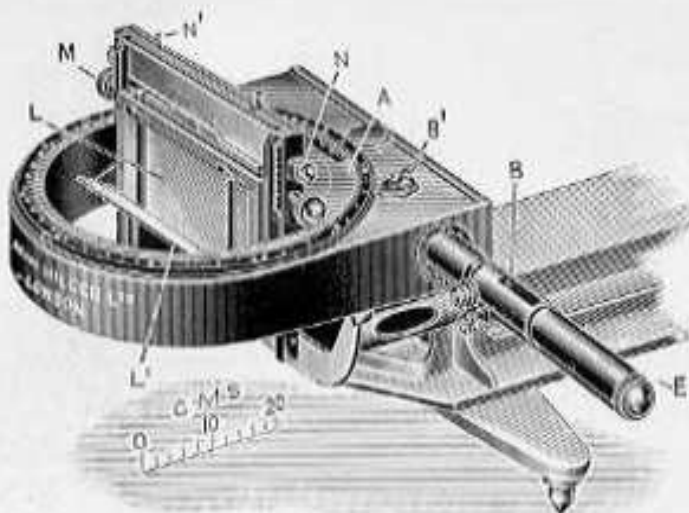

THE CAMERA

A = camera, B = slit, B' = mount for reflecting prism, E = condenser mount on slit, L = dark slide, M = rack and pinion motion for dark slide, N = rack and pinion motion for movable diaphragm for use with grating arrangement. This diaphragm may be varied in width. N¹ = scale rod for indicating position of movable diaphragm, L¹ = focussing mirror.*

The case is constructed in well seasoned wood varnished outside and blacked inside. It may be completely removed when required.

* This mirror is not now fitted, other means of showing the spectrum are provided.

ADAM HILGER, Ltd., 98 Kings Road, Camden Road, London, N.W.1

Screw Adjusted Model.—This instrument is exactly the same as the hand adjusted instrument with the addition of screw adjustments for focussing the carriage. Both carriage and rotating table adjustments are thus made by handles outside the case, the scales being read through a large glass window in the side (with cover when not in use). Also in place of the vernier there is a divided drum mounted outside the case on the handle spindles. *It is hardly necessary to point out the advantage of operating the adjustments without having to open the case, more particularly for the larger instruments where uniformity of temperature is essential for good definition.*

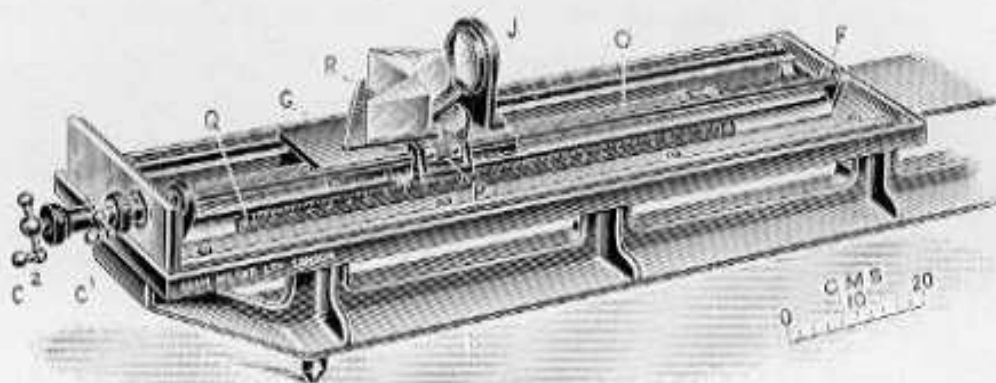

THE SLIDE AND OPTICAL MOUNTING

C^1 C^2 —adjusting handles with divided drums, F—slide, G—carriage for optical train, J—achromatic lens and mount E 200, O—screw operated by handle C^2 for moving optical system along axis of instrument, P—worm operated by handle C^1 for rotation of optical mounting, Q—scale with vernier reading to 0.01 inches, R—Littrow mounting E 242 with one 30° prism and one 60° prism.

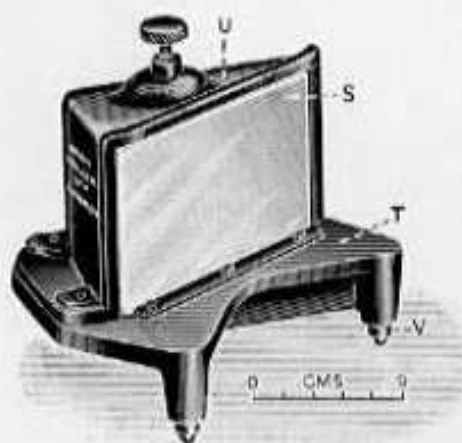

30° PRISM IN MOUNT, FOR LITROW MOUNTING; E 233

With the exception of the refracting face the prism is surrounded by metal, this design having been adopted as a result of our investigations into the effect of temperature on refractive index, variations of which lead to impairment of definition. The geometric mounting enables the prism in its mount to be removed and replaced in precisely the same position. S=30° prism, T=base, U=cover, V=locating feet.

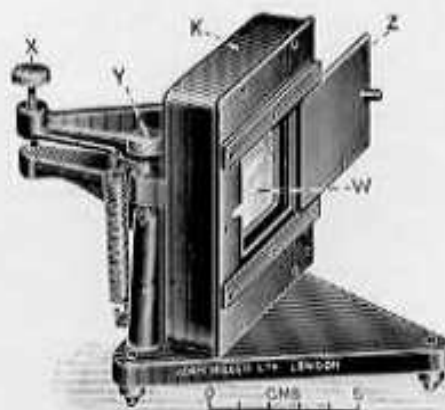

PLANE GRATING WITH MOUNT; E 251

The grating is enclosed with the exception of the ruled area, which is disclosed by opening a sliding shutter. The adjustments provide for inclination of the grating about two horizontal axes, one in, and one at right angles to, the plane of the grating. K=casing for grating, W=grating, X and Y=adjusting screws, Z=sliding shutter.

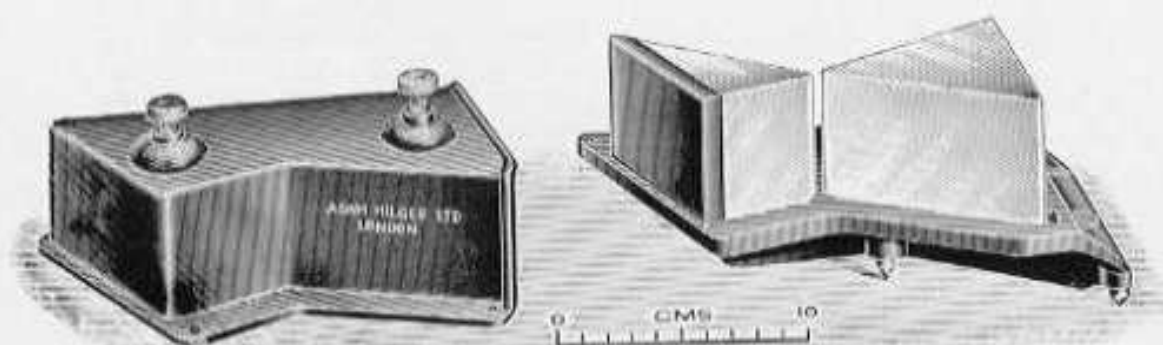

60° AND 30° PRISMS WITH MOUNT, FOR LITTROW MOUNTING; E 242

The notes referring to the illustration of the 30° prism in mount apply also to this figure. The cover is shown removed and at one side.

DESCRIPTIONS OF DETAILS COMMON TO ALL INSTRUMENTS

Slit and Condenser.—The slit is generally similar to our standard F 31, but of rather simpler construction. A Hartmann diaphragm is provided.

Incorporated with the slit is a spherical condenser of quartz specially designed for each size of instrument and carefully adjusted. The position for the light source is then correct when its image is on the slit, so that the adjustment of alignment usually associated with spectrographs is eliminated. A sphero-cylindrical condenser can also be supplied.

Girder Base.—Each model is mounted complete on a cast iron base of girder form.

Trolley stand to support instrument.—A specially designed support can be supplied with large casters to enable the instrument to be moved about readily. The construction is such that the instrument may be moved about over an uneven floor without fear of straining the girder bed or putting the instrument out of adjustment. (See p. E 36.)

DESCRIPTIONS OF ALTERNATIVE OPTICAL SYSTEMS

Whichever model and size be selected the following details of construction of the interchangeable parts are the same (see Fig. B., p. E 29).

1. *Concave Grating Mount.*—This is of the Eagle type (see p. E 38). Adjustment is provided for rotation about two horizontal axes; this, combined with the rotating table on which the grating stands, gives all necessary adjustment.

2. *Quartz Prism and Lens Mount.*—These prism mounts are of very simple construction and arranged so that they may be interchanged with the other mounts for appropriate grating or prism, and used together with the lens, without readjustment of the instrument when once it has been calibrated. The instrument then becomes a Littrow Spectrograph, which is optically almost identical with our E 383 Spectrograph (see page E 8).

3. *One Glass Prism and Lens Mount.*—This mount is similar to the quartz prism mount.

4. *Two Glass Prisms and Achromatic Lens Mount.*—This mount is similar to the One Prism mount, but an achromatic lens is used in this combination. The achromatic lens is also suitable for use in the Plane Grating Mount described below.

The 30° and 60° prism arrangement is inserted by us as many enquirers have shown an interest in having a prism system giving considerable angular dispersion.

We wish, however, to point out that the linear dispersion measured on the plate is very little greater with the two glass prisms than with the one glass prism (see table, page E 35). This is due to the photographic plate being at considerable obliquity to the axis of the instrument in the latter case. The exposures are approximately the same with the two arrangements. The chief advantage therefore with the two-prism arrangement is that the photographic plate is used at nearly normal incidence.

5. *Plane Grating and Achromatic Lens Mount.*—The mount for the plane grating is exactly the same as that for the concave grating mount. The achromatic lens is the same as that used with the two-prism system.

Details of design are clearly shown in the illustrations on pages E 30-33 which show the screw adjusted model.

SPECIFICATIONS.

DIMENSIONS OF OPTICAL WORK.

(All dimensions are in centimetres.)

| Nominal Focus. | 100 cms. | 150 cms. | 300 cms. |
|-----------------------------|---------------------|---------------------|----------------------|
| <i>Concave Grating.</i> | | | |
| Size of Ruled Area | 5 × 3.5 | 5 × 3.5 | 8 × 5.0 |
| Radius of Grating | 100 | 150 | 300 |
| Catalogue No. | K 18 | K 19 | K 22 |
| Size of 30° Quartz Prism | 6.5 face × 4.1 high | 9.5 face × 5.6 high | 9.5 face × 5.6 high |
| Aperture of Lens | 5.0 | 7.5 | 7.5 |
| Focus of Lens λ5890 | 100 | 152 | 297 |
| *Glass 30° Prism | 6.5 face × 4.1 high | 9.5 face × 5.6 high | 13.0 face × 7.6 high |
| Aperture of Lens | 5.0 | 7.5 | 10.0 |
| Focus of Lens λ5890 | 100 | 152 | 292 |
| Glass 30° and 60° Prism | 6.5 face × 4.1 high | 9.5 face × 5.6 high | 13.0 face × 7.6 high |
| Aperture of Achromatic lens | 5.0 | 7.5 | 10.0 |
| Focus of Lens λ5890 | 100 | 155 | 295 |
| <i>Plane Grating.</i> | | | |
| Size of Ruled Area | 5 × 3.5 | 5 × 3.5 | 8 × 5.0 |
| Catalogue No. | K 14 | K 14 | K 15 |
| Aperture of Achromatic lens | 5.0 | 7.5 | 10.0 |

* Very much larger glass prisms and lenses can be quoted for if required, where very large aperture is needed.

DISPERSION.

| | Approximate Range of Spectrum obtainable. | Approximate Linear Dispersion measured on the Plate, cms. | | | | | |
|---|---|---|----------------|----------------|----------------|----------------|----------------|
| | | F 100 cms. | | F 150 cms. | | F 300 cms. | |
| | | 8,000 to 4,000 | 8,000 to 2,000 | 8,000 to 4,000 | 8,000 to 2,000 | 8,000 to 4,000 | 8,000 to 2,000 |
| Eagle Mounting with Concave Grating of 14,400 lines per inch | from the extreme violet to | | | | | | |
| 1st Order . . . | 26,000 A | 23 | 35 | 35 | 52 | 69 | 104 |
| 2nd Order . . . | 13,000 A | | | | | | |
| 3rd Order . . . | 8,800 A | | | | | | |
| 4th Order . . . | 6,500 A | | | | | | |
| 5th Order . . . | 5,300 A | | | | | | |
| Littrow Mounting with Quartz Prism and Lens . . . | 2050 A to 8000 | 4 | 38 | 9 | 57 | 19 | 114 |
| Littrow Mounting with One Glass Prism and Lens . . . | 3800 A to 8000 | 21 | | 32 | | 64 | |
| Littrow Mounting with Two Glass Prisms and Achromatic Lens . | 3500 A to 8000 | 23 | | 36 | | 70 | |
| Littrow Mounting with Plane Grating and Achromatic Lens - (1st Order) | 3500 A to 8000 | 23 | | 35 | | 69 | |

SCHEDULE OF CATALOGUE NUMBERS.
In ordering please quote catalogue number and size.

**BASIC INSTRUMENTS WITHOUT DISPERSING SYSTEMS
AND WITHOUT DARK SLIDES.**

| Nominal Focus. | 100 cms. | 150 cms. | 300 cms. |
|------------------------|----------|----------|----------|
| Hand Adjusted | E 178 | E 181 | E 184 |
| Screw Adjusted | E 179 | E 182 | E 185 |

OPTICAL TRAINS.

(Any or all of which may be added as required.)

| Nominal Focus. | 100 cms. | 150 cms. | 300 cms. |
|--|------------|------------|------------|
| | All models | All models | All models |
| Concave Grating with Mount | E 212 | E 215 | E 218 |
| Quartz Prism, Lens and Mount | E 221 | E 224 | E 227 |
| One 30° Glass Prism, Lens and Mount | E 230 | E 233 | E 236 |
| One 30°, one 60° Prism and Mount | E 239 | E 242 | E 245 |
| Plane Grating and Mount | E 248 | E 251 | E 254 |
| Achromatic Lens and Mount, suitable for either two prism, or Plane Grating Spectrographs | E 257 | E 260 | E 263 |

DARK SLIDES FOR BOTH MODELS.

Both models take plates, 10" × 4" (25.4 × 10.1 cms.); films, 10" × 2" (25.4 × 5.08 cms.).

| Nominal Focus. | 100 cms. | 150 cms. | 300 cms. |
|--|----------|----------|----------|
| Dark Slide for Films, Curvature suitable for Concave Grating | E 267 | E 269 | E 271 |
| Dark Slide for Plates, suitable for Concave Grating | E 273 | E 275 | E 277 |
| Dark Slide suitable for Quartz Prism | E 279 | E 281 | E 283 |
| Dark Slide suitable for one Glass Prism | E 285 | E 287 | E 289 |
| Dark Slide suitable for two Glass Prisms or Plane Grating | E 291 | E 293 | E 295 |

| Nominal Focus. | 100 cms. | 150 cms. | 300 cms. |
|-----------------------|----------------------|----------------------|----------------------|
| Trolley Stand | Both models E 302 | Both models E 303 | Both models E 304 |

Schedule of Catalogue Numbers—(continued).

TROPICAL FINISH TO INTERCHANGEABLE SPECTROGRAPHS.

These spectrographs can be supplied with the woodwork made suitable for use in the tropics. The framing and dark slides are made out of selected mahogany and brass bound. The panelling is of three ply wood and the whole case is specially varnished. The adjusting screw is protected from rusting by being "coslettized."

| Catalogue No. | Nominal Focal Length Either Model (Hand or Screw Adjusted.) | Price. |
|---------------|--|--------------------|
| E 375. | 100 cms. | £5 10 0 extra. |
| E 376. | 150 cms. | 6 10 0 " |
| E 377. | 300 cms. | 7 15 0 " |
| E 378. | Dark Slides supplied separately | 0 17 6 extra each. |

SPECIAL NOTES

In ordering, customers should state:

- (a) Name and catalogue number of basic instrument required from the Schedule on p. E 36.
- (b) Name and catalogue number of optical trains required from table on p. E 36.
- (c) Name and catalogue numbers of dark slides corresponding to *all* the optical trains ordered, from the table on p. E 36.
- (d) If Trolley stand is required.

The prices may be found from our current Price Sheet by reference to the catalogue numbers.

OTHER GRATING SPECTROGRAPHS

EAGLE MOUNTING FOR CONCAVE GRATING SPECTROGRAPHS
AS USED IN THE SPECTROGRAPHS WITH INTERCHANGEABLE OPTICAL
SYSTEMS, described on pp. E 29 to E 37.

(No. 1 in Fig. B, page E 29.)

(See Paper by A. Eagle "On a New Mounting for a Concave Grating,"
Astrophys. Journ., 31, page 120, March 1910.)

In comparison with the classical Rowland mounting, the Eagle mounting has the following advantages :

- (1) It occupies less space.
- (2) No darkened room is necessary.
- (3) Spectra on either side of the normal may be used with equal facility; a point of some value, as it may happen that the best third-order spectrum is on the opposite side to the best first-order spectrum.
- (4) Everything being on the same axis, great rigidity is obtained.
- (5) It is much easier to ensure uniformity of temperature. This is of capital importance in making long exposures with the larger models.
- (6) Higher orders are obtained.

Mr. Eagle has developed in detail in the above-mentioned paper the comparison between the two methods of arranging the diffraction grating.

In addition to the Interchangeable Spectrographs with gratings, already referred to, we make an Eagle Mounting Grating Spectrograph suitable for a grating of 650 cms. radius and 6 inches diameter.

With gratings of this radius the camera and the slides with screw motion, etc., are to be mounted on separate concrete or brickwork supports instead of both on one girder, and the camera and slides are designed for this purpose. A drawing of the necessary brickwork is sent on receipt of every order for one of these instruments. In addition to the wooden cover provided for the smaller size of grating mounting, a second inner cover is provided further to retard the temperature variations which in all large grating spectrographs are a source of great inconvenience if not provided against. The camera is arranged to take plates 40 × 4 cms., and all necessary adjustments are provided. The slit is our No. F 31 size.

E 18.—Concave Grating Spectrograph including best quality grating.

E 74.—Concave Grating Spectrograph E 18 without the screw for the focussing adjustment and without the rods can be supplied at a considerable saving of expense.

For stigmatic mountings for concave gratings, according to the system of Meggers and Burns, *Bureau of Standards Scientific Paper*, No. 441, 1922, see p. E 39.

STIGMATIC CONCAVE GRATING SPECTROGRAPH, AS USED BY
MEGGERS AND BURNS

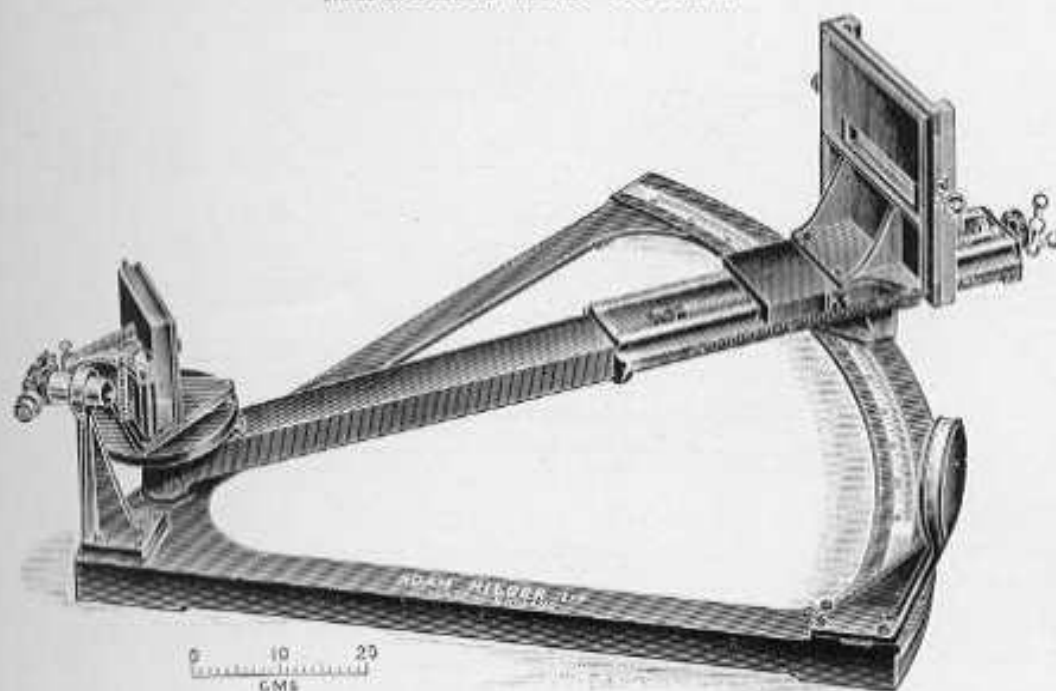

Fig. E 367

It was first pointed out by Wadsworth * that a stigmatic image is obtained with a concave grating if it is used in parallel light and spectra observed near the normal to the grating. A concave mirror was used in this manner by Fabry and Buisson,† and an instrument modelled on the lines of theirs has been described by Meggers and Burns.‡ The instrument here described is based on their design, and is provided with a 2 metre concave grating.

This instrument takes photographic plates $6\frac{1}{2}'' \times 4\frac{1}{4}''$. The dark slide has vertical movement by rack and pinion, with dividing, for taking several spectra on one plate.

The slit, grating mount, and concave mirror mount are fixed on a massive arc shaped base, whose outer edge forms a track for the arm bearing the plateholder with this screw focussing adjustment. The grating mount has screw adjustments about two horizontal axes, one in the plane of the grating and the other perpendicular to it. The slit provided is of our F 31 type.

No cover is provided for the apparatus, which is customarily used in a dark room. All necessary adjustments are provided.

E 367.—Stigmatic Concave Grating Spectrograph, with grating of 2 metres radius of curvature, Cat. No. K 21; ruled area 8×5 cms.; 14,400 lines per inch.

E 49.—Stigmatic Concave Grating Spectrograph, with grating of 3 metres radius, Cat. No. K 22; ruled area 8×5 cms.; 14,400 lines per inch.

The construction of this instrument is similar to that of the E 367 described above; the dimensions being increased to suit the greater radius of curvature of the grating. A plateholder to take photographic films $10'' \times 2''$ is fitted in place of that for plates $6\frac{1}{2}'' \times 4\frac{1}{4}''$.

* *Astrophys. J.* 3, pp. 54-58, 1896.

† *J. de Phys.* (4) 9, p. 940, 1910.

‡ *Bureau of Standards Scientific Paper*, No. 441, 1922.

FLUORESCENCE SPECTROGRAPH

DR. S. JUDD LEWIS' FLUORESCENCE SPECTROGRAPH

BIBLIOGRAPHY

S. J. Lewis, *Journ. Soc. Dyers and Colourists*,

August 1918, No. 8, Vol. XXXIV. April 1922, No. 4, Vol. XXXVIII.
 March 1922, No. 3, Vol. XXXVIII. February 1924, No. 2, Vol. XL.

The optical system of the activating portion of the Fluorescence Spectrograph consists of a collimator with quartz lens of 24 inches (610 mm.) focus 51 mm. diameter, 60° quartz cornu prism 41 mm. high × 65 mm. long face and quartz camera lens 51 mm. diameter.

The slit is our F 31, see page F 6. The fluorescent substance to be examined is placed in the form of crystal, powder or liquid, in a quartz cell occupying the position where the photographic plate would be placed normally. The spectrum falls on the lower surface of the fluorescent substance, and the fluorescent glow is photographed by an ordinary camera, with wide angle photographic lens, placed below.

The spectral region covered by the quartz cell is from 2100 to 4000 Å, the length being 158 mm. A larger quartz cell and mounting to cover 8000 Å can be supplied at extra cost.

It should be observed that the screen may take any form desired, and not necessarily the quartz cells specified.

The photographic camera is designed for 6½" × 4¾" plate and is provided with rack and pinion motion so that several exposures may be obtained on one plate.

CATALOGUE NUMBERS

- E 350.—Fluorescence Spectrograph, complete with one quartz cell
 (and one replacement quartz plate)
 F 370.—Tungsten Electrodes, per pair
 E 352.—Larger quartz cell and mounting to cover 2100 Å to 8000 Å

VACUUM SPECTROGRAPHS

NOTES:

Gratings.—Each Vacuum Spectrograph is tested with its own grating in our works and every grating supplied by us in such spectrographs is guaranteed to be of good quality for the vacuum region. Gratings which are of first quality for the visible and ordinary ultra-violet regions are frequently useless for the vacuum region, while gratings which in the second and third orders of the visible are of second quality, are often of first quality in the vacuum region. For this reason we do not in accepting orders for vacuum spectrographs, undertake to deliver them with gratings registered by the ruling laboratory as of first quality. We fully guarantee the actual performance of the grating supplied when used in the vacuum spectrograph up to 8000 Å in the first order.

ONE METER GRATING VACUUM SPECTROGRAPH

(See F. Simeon and C. F. Smith, *Rev. Sci. Inst.*, vol. i., pages 512-516, 1930;
 Sawyer, *J.O.S.A. & R.S.I.*, 15, 303-308, November, 1927.)

The arrangement of this spectrograph follows the lines laid down by Sawyer in the paper cited above, but also embodies features which do not appear in his design.

ADAM HILGER, Ltd., 98 Kings Road, Camden Road, London, N.W. 1

The grating used is the K 35, which is a circular, polished speculum mirror, 7 cms. in diameter and of 100 cms. radius of curvature, ruled with about 14,400 lines per inch, and its mount is provided with all necessary adjustments.

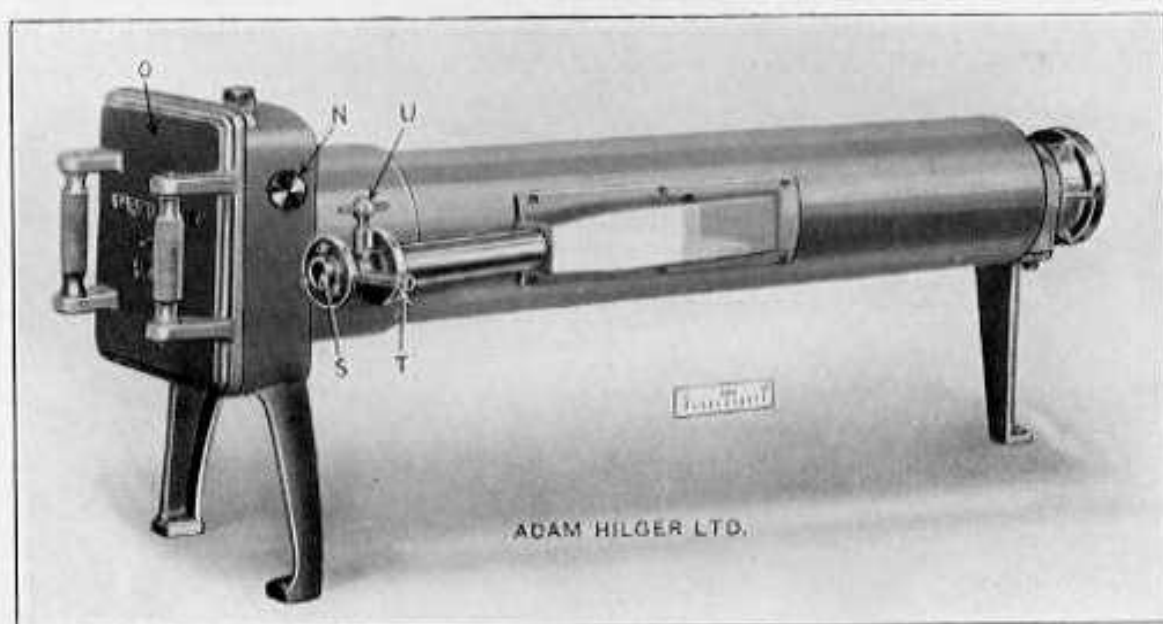

Fig. E 368

Following Sawyer's design the slit is mounted on a side tube which is attached to the main tube at as small an angle as is practicable. Although the conditions for normality are less perfect than in the older designs the error introduced is still negligible. The cover plate to the dark slide is completely removable so that the grating itself and the visible spectrum formed by it may be observed by eye for rapid adjustment of the grating. The dark slide itself is hinged at the end nearest to the slit and the grating is adjusted so that the central image is focussed upon the axis of the hinge and is recorded on the plate. This is the only adjustment for focus that is necessary and it can be performed to a close approximation by visual inspection. The plate (16.3×3.8 cms.) is of sufficient length to record lines in the neighbourhood of 2500 Å without evacuating the instrument, and thus the remaining adjustment of fixing the inclination of the plate to the axis of the instrument may be rapidly performed. A scale is provided for this adjustment. The plate is bent to a curve of one metre radius, which can be done safely with extra thin glass.

Among the special features which we have introduced in this instrument is an efficient means of raising and lowering the plateholder, so that more than one spectrum can be taken on one plate, a convenience when, for instance, absorption spectra are to be studied. There is also a means of withdrawing and replacing the shutter of the plateholder *in vacuo*, so that the instrument may be used in a well lighted room.

The slit system is so arranged that gas discharge spectra may be photographed without using a window. A cone fitting is supplied for the adaptation of an F 596 or F 280 Vacuum Arc Lamp (page E 46). A tap is provided whereby the light source can be cut off from the spectrograph while it is being prepared.

E 368.—One Metre Vacuum Grating Spectrograph.

A full, illustrated description will be sent post free on application (Hilger Publication No. 123).

ADAM HILGER, Ltd., 98 Kings Road, Camden Road, London, N.W. 1

TWO METRE GRATING VACUUM SPECTROGRAPH

The desirability of having means of resolving and measuring the separation of some of the complex lines (*e.g.* those in the carbon spectrum) has caused us to put on the market a vacuum grating spectrograph having a grating with 200 cms. radius of curvature. The construction is massive. The mount for the grating is fitted with all necessary adjustments (Fig. E 422a).

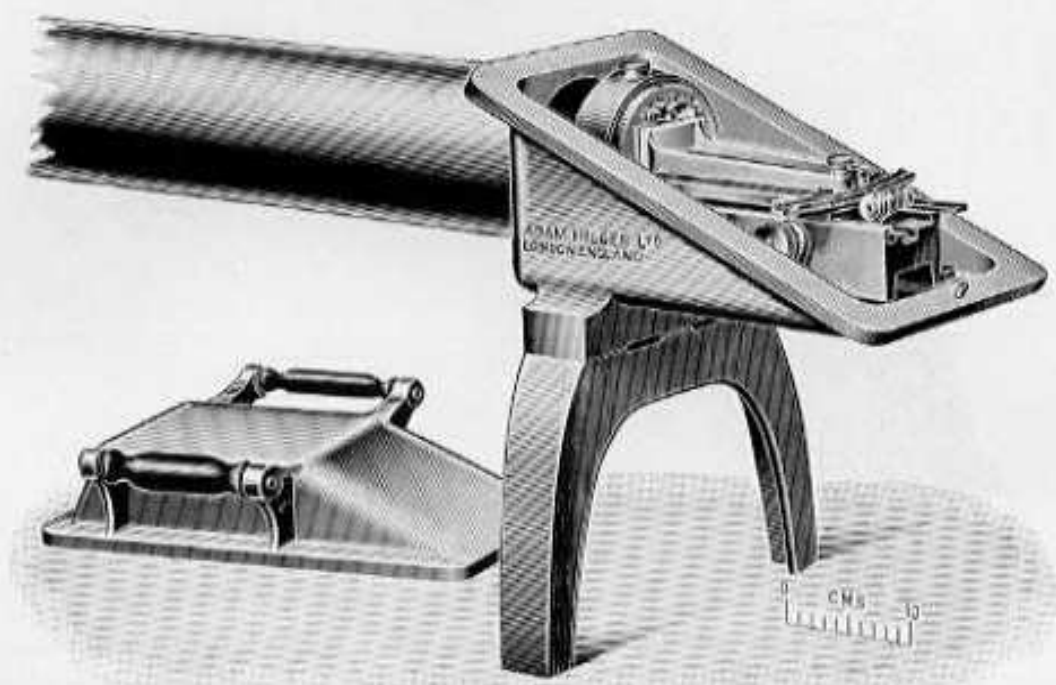

E 422a

The general design of this instrument is similar to that of the one metre instrument E 368, and has similar adjustments and movements. It takes a $10'' \times 2''$ photographic plate, and includes sufficient of the spectrum on it to permit of adjustment without evacuating the instrument.

E 422.—New Design Two Metre Grating Vacuum Spectrograph.

GRAZING INCIDENCE GRATING VACUUM SPECTROGRAPH

(See "Serienspektren der Leichtesten Elemente in extremen Ultraviolett,"
Algot Ericson and Bengt Edlen, *Zeit. f. Phys.* 59, 656-679, 1930)

Two principal difficulties in the spectroscopy of the extreme ultra-violet have been the obtaining of large dispersion and of sufficient reflection from the gratings used. Both are overcome in this new design of spectrograph, which has been freely adapted from an instrument designed by Prof. M. Siegbahn and described in the paper cited above. In this paper it is stated that the minimum wavelength that can be expected to be photographed with the classic type of Vacuum Grating Spectrograph, in which the incident beam is approximately normal to the grating surface, is about 300 Å, and that only in favourable circumstances. With the new type of instrument, photography was carried as far as 100 Å, and it is suggested that this limit is imposed by the light source (a spark in vacuum) rather than by the spectrograph, subsequent measurements as far as 68 Å having been made.

In this new arrangement the slit and photographic plate are both situated upon the Rowland circle of a concave, ruled, diffraction grating, in such a manner that the angle between the grating surface and the incident beam is small. Total reflection

ADAM HILGER, Ltd., 98 Kings Road, Camden Road, London, N.W. 1

can then be anticipated for wavelengths down to 100 Å or less, irrespective of the age of the grating. The photographic plate has a similar curve to the Rowland circle, in order that the spectrum may be in focus throughout its length.

The dispersion is very large at incidences such as these, though it is not linear.

In the original instrument described in the paper cited above the plateholder was moved around an arc of the Rowland circle in order to photograph various spectral regions. Hence we have adopted this arrangement in the present instrument.

The body of the instrument consists of massive castings connected by tubes, treated as are our other vacuum instruments to permit of easy evacuation. The plateholder is constructed on similar lines to that used in our Vacuum Grating Spectrographs. It takes a plate 10 × 2 ins., on which several exposures can be made, which can be raised or lowered by a rack motion operated through an airtight bearing by a milled knob outside the instrument.

The mount for the grating, which is readily accessible through a removable cover plate with carefully ground flanges, is provided with all necessary adjustments.

The slit system is a modification of the double slit introduced by us on our vacuum grating spectrographs in order that the light source and the spectrograph may, when desired, be maintained in different states of exhaustion without the interposition of any windows between them. The separation of the jaws of the primary slit is adjustable from outside the spectrograph, and a removable adjusting device is provided for setting it vertical.

This instrument can be fitted with a grating ruled in the laboratories of Prof. M. Siegbahn.

E 423.—Grazing Incidence Vacuum Grating Spectrograph complete with K 20 Ruled Diffraction Grating (2 metres radius).

E 525.—Grazing Incidence Vacuum Grating Spectrograph with Grating of Three Metres Radius.

FLUORITE VACUUM SPECTROGRAPH WITH WAVELENGTH SCALE

This instrument combines those features which we have found desirable in our experience with vacuum spectrographs both with fluorite and ruled grating dispersing systems.

The optical parts are as large as can be hoped to obtain from perfectly clear fluorite now in stock, the prism being 0.67" high with 0.87" length of face. The focal lengths of the lenses are 10" each for collimator and camera, so as to give a dispersion of 6" from $\lambda 1400$ to $\lambda 2300$. The size of the plate adopted is $6\frac{1}{2} \times 1\frac{1}{2}$ " (16.3×3.8 cm.), and the plateholder is identical with that used on the E 368 Vacuum Grating Spectrograph, including mechanical means for moving the plate without breaking the vacuum, so that a number of exposures may be made.

The slit system is the same as that used on the E 368 instrument. The main slit is adjustable for width, and a second slit is provided with substantial pump connection between, so that a windowless gas discharge tube can be used as source.

There is a wavelength scale which can be printed on to the plate in the same way as is done with our quartz spectrographs. Illumination is made in the same way also, except that a window is provided to ensure maintenance of the vacuum. This scale is a feature which we feel sure will appeal to chemists who purpose undertaking absorption measurements in this important, but almost unexplored, region.

ADAM HILGER, Ltd., 98 Kings Road, Camden Road, London, N.W. 1

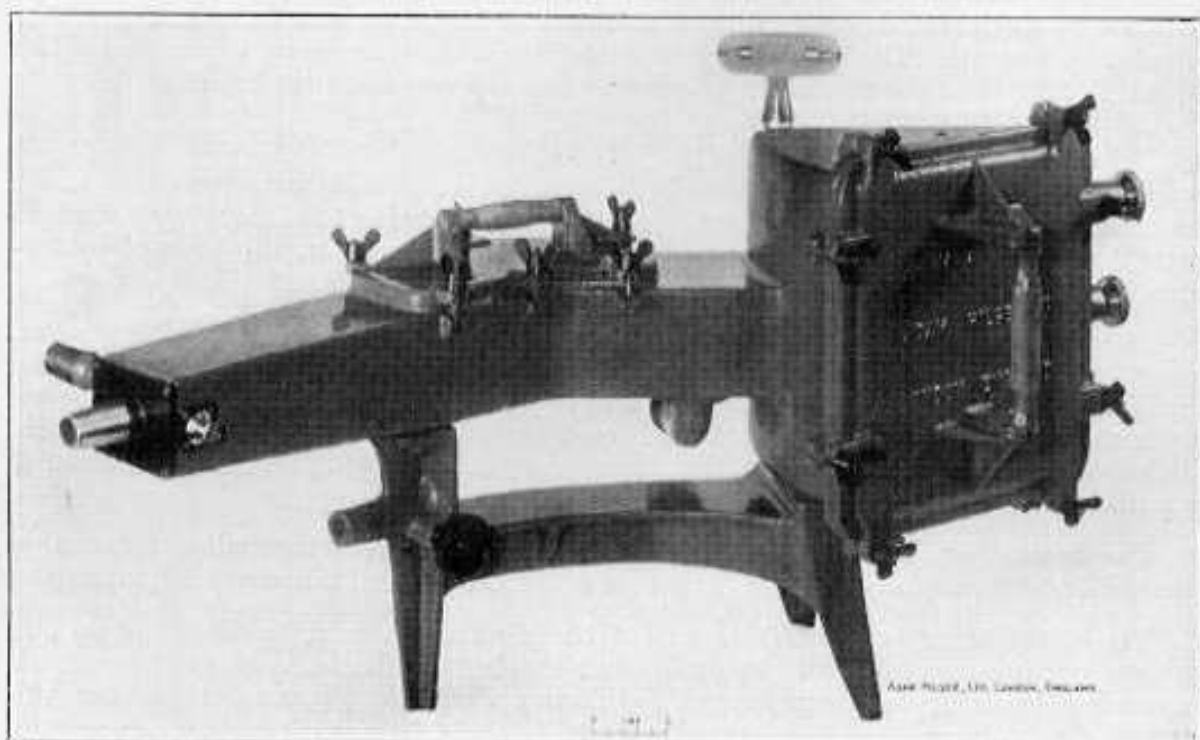

Fig. E 419

A second special feature consists of an absorption tube 15 mm. long, placed between the collimator lens and the prism. It is provided with fluorite windows, and has a cone fitting on a separate pump connection through the base of the spectrograph. This position of the absorption tube, although unusual, has been chosen in view of the difficulties which have been encountered by many in connection with fluorite plates used in close proximity to a vacuum light source.

E 419.—Fluorite Vacuum Spectrograph with Wavelength Scale, including one absorption tube.

VACUUM SPECTROGRAPH WITH FLUORSPAR PRISM AND LENSES

GIVING THE REGION 1500 TO 1935Å SIMULTANEOUSLY IN FOCUS ON A QUARTER PLATE

EASILY INTERCHANGEABLE QUARTZ PRISM AND LENSES CAN BE SUPPLIED GIVING THE REGION 1850 TO 13,000Å SIMULTANEOUSLY IN FOCUS ON A QUARTER PLATE

The spectrograph, removed from the vacuum chamber, is shown in Fig. E 489. It is closely similar to the Hilger E 484 All-metal Small Quartz Spectrograph, except that it has a fixed slit of 0.03 mm. width, and the focal lengths of the quartz lenses are such that the length of the spectrum, when the quartz optical system is used, is reduced to 7/10ths of that of the standard instrument. No adjustment of focus is necessary on changing over from quartz to fluorspar or vice versa.

A wavelength scale, which prints on the negative itself, is provided for the fluorspar system. Wavelengths of lines obtained with the quartz system can be deduced fairly simply, for the geometry of the quartz optical system is identical with that of the fluorspar one and hence the wavelength of a line obtained with the former is that for which the refractive index of quartz is the same as is that of

ADAM HILGER, Ltd., 98 Kings Road, Camden Road, London, N.W. 1

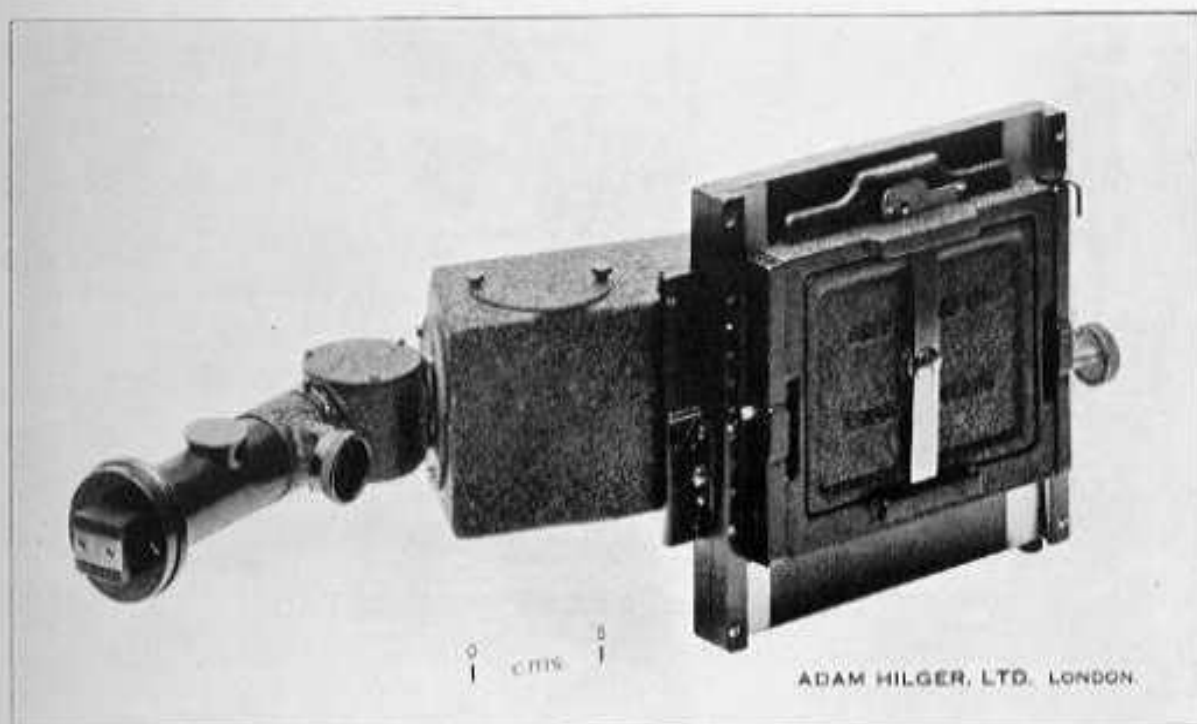

Fig. E 489

fluorite for the wavelength indicated on the wavelength scale. A graph is supplied giving the refractive indices for the two materials throughout the spectral region covered by the spectrograph.

The lengths of spectrum with the two optical systems are as follows :

Fluorite Optical System ; * 1335 to 1936A, about 78 mm. (43 mm. from 1500A).

Quartz Optical System ; 1850 to 5700A, about 58 mm.

The interchange of the optical systems is very easily made. The lenses, mounted in brass mounts, drop into position in recesses provided in the spectrograph and are then in adjustment. The prism is removed by unscrewing the lid of the prism box, when the prism with its mount can be lifted out. The position of the prism mount is determined by locating pins. A single screw secures the prism mount to the body of the spectrograph, but this screw need not be used except for transit.

The vacuum case for the Spectrograph consists of a flanged iron tube, with a standard coned nozzle for connection to the pump, and an aperture (with cover plate) for interchange of the optical systems. The end adjacent to the slit is fitted with a cover and flanged aperture to which such auxiliary apparatus as a vacuum arc, absorption tubes, etc., can be applied. The camera end has a cover which is removable for inserting the plateholder. The plateholder can be moved vertically by a milled head outside the case, for taking a series of spectra, without letting down the vacuum. A total movement of 2 inches (51 mm.) is provided, so that fifteen or more spectra can be taken on the one plate. The wavelength scale can also be operated from outside without letting down the vacuum, and is illuminated by a 4-volt lamp mounted within the spectrograph, terminals for this lamp being provided outside the vacuum case.

* The scale is engraved to read this wavelength, but we cannot guarantee that wavelengths lower than 1500A can be recorded with every instrument.

The plateholder takes quarter plates ($4\frac{1}{4} \times 3\frac{1}{4}$).

- E 489.—Vacuum Spectrograph in vacuum case, as described above ;
basic instrument without optical work, but including
wavelength scale for the fluorite optical system ...
- E 490.—Fluorite Optical System
- E 491.—Quartz Optical System

Every instrument is completely adjusted and evacuated in our own laboratory and photographs are taken in the vacuum region before despatch.

Accessories can be provided for this instrument converting it into a Vacuum Spectrophotometer of the "Spekker" type. Price on application.

VACUUM ARC LAMPS

SIMPLE VACUUM ARC LAMP FOR METALS

This consists of a water-cooled jacket, which can be applied to the slit of the Vacuum Grating Spectrograph. The electrodes are attached to rods which pass through an insulated vacuum-tight fitting in the jacket, and are designed to allow of motion for adjusting and striking the arc. The position of the electrodes when touching is such that the light produced is sufficiently close to the slit to allow of the maximum aperture being used.

F 280.—Simple Vacuum Arc Lamp for Metals.

STANDARD VACUUM ARC LAMP

This vacuum arc lamp has been specially designed to be as convenient as possible in use, and to be equally serviceable whether used in conjunction with a vacuum spectrograph in the far ultra-violet or with a spectrograph in air. The adjustments are simple and efficient.

The main cylindrical body is water-jacketed and provided with two window apertures and a standard taper tube for connection with the evacuating pumps. One window aperture has a glass disc sealed into it, and is used for observation and alignment of the arc, while the other, diametrically opposite to it, is normally open and has a standard conical tube fitting those on the slits of our Vacuum Spectrographs (E 368, E 419, etc.). For use with spectrographs not having this fitting, or outside the vacuum region, a quartz or fluorite disc can be fitted.

The top and bottom end plates of the lamp carry the electrode holders with their adjustments. Each is provided with a rubber gasket and, when clamped by the wing nuts and screws, makes an air-tight joint. The electrode holders are attached to rods passing through packing glands in the end plates. Outside the arc lamp each of the two rods is provided with a rack and pinion motion for adjusting the separation of the electrodes. These are so arranged that the rods may be

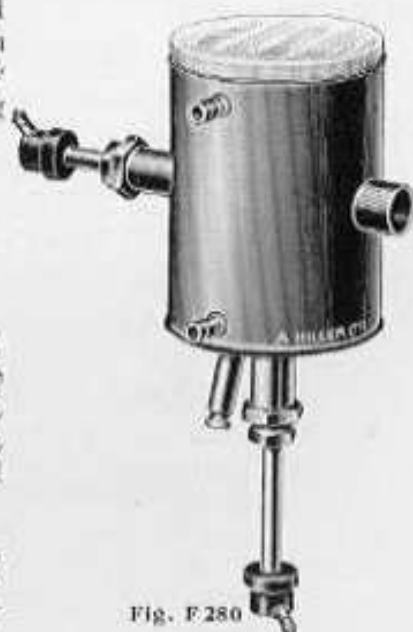

Fig. F 280

rotated through a small angle and clamped in the desired position. Substantial milled heads are fitted to all the adjustments for ease of operation, and they may be used while the arc is running, as the electrode holders are carefully insulated from them.

The electrode holders have screw clips capable of holding any rods under 7 mm. diameter. They are well insulated, and can be rotated around the adjusting rods and clamped as desired. Electrical connection is made to them via substantial terminals passing through insulating bushes in the end plates.

The vertically opposed arrangement of the electrodes makes the arc comparatively easy to adjust. It is very easily and quickly taken apart for cleaning or for the insertion of fresh electrodes.

A boss on one side of the arc lamp can be readily attached to a Gramont Arc and Spark Stand F 580 in place of the electrode holders of the latter, or to the stand F 662 (below).

F 596.—Standard Vacuum Arc Lamp.

F 662.—Stand with Raising and Lowering Motion, for Standard Vacuum Arc Lamp F 596.

ACCESSORIES FOR VACUUM SPECTROGRAPHS

We can supply the following accessories for the foregoing Vacuum Spectrographs.

SCHUMANN PLATES of our own manufacture. These plates are exceedingly sensitive in the region of the spectrum below 2000 Å, and are especially suitable for use in the regions covered by the foregoing spectrographs. They are reasonably robust, and no special or awkward technique is required for their use. They can be supplied in suitable sizes for any of the foregoing instruments. (For details, see special leaflet, which will be sent post free on application. Hilger Publication No. 42/2.)

F 597.—Schumann Plates, 16.3 cms. \times 3.8 cms., on extra thin glass (about 0.6 mm. thick). *Suitable for Spectrograph E 368.*

F 677.—Schumann Plates, 10 ins. \times 2 ins. (25.4 \times 5.1 cms.) on extra thin glass (about 0.6 mm. thick). *Suitable for Spectrographs E 422 and E 423.*

F 694.—Schumann Plates, 6½ ins. \times 1½ ins. on extra thin glass (about 0.6 mm. thick). *Suitable for Spectrograph E 419.*

F 94.—Schumann Plates, 4¼ ins. \times 3¼ ins. (10.8 \times 8.2 cms.). *Suitable for Spectrograph E 489.*

VACUUM PUMPS.—See Catalogue F.

F 353.—Large Bore Discharge Tube for use as a vacuum gauge.

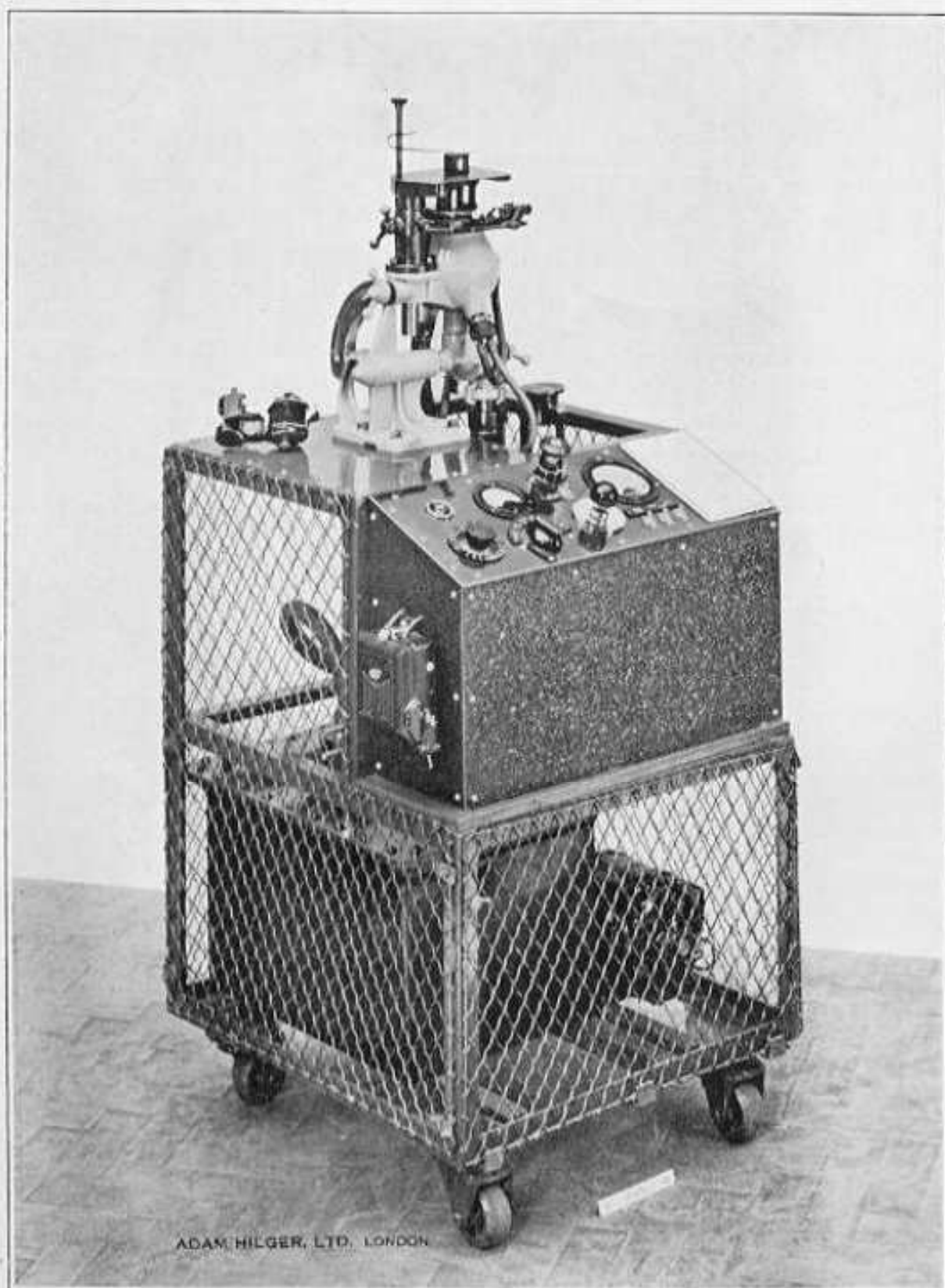

Fig. E 503. The Dexrae Industrial Demountable X-ray Unit

ADAM HILGER, Ltd., 98 Kings Road, Camden Road, London, N.W. 1

X-RAY CRYSTALLOGRAPHS AND SPECTROGRAPHS

THE DEXRAE INDUSTRIAL X-RAY UNIT

(A full description of this instrument will be sent on request.)

See Fig. E 503, opposite.

This unit is designed for the investigation and control of industrial production problems in metallurgy by means of X-ray structural analysis. It is a completely self-contained outfit, mounted upon a substantial trolley stand that can be wheeled from place to place.

The camera equipment is bolted to a continuously evacuated, shock-free, hot cathode X-ray tube. The latter is clamped to a bracket which allows for rotation through 90°. The anticathode is so constructed that each of its four faces in turn can be brought into use. The faces are plated with copper, cobalt, chromium and molybdenum respectively, and a filter corresponding with each is contained in the mounting of the beryllium window of the tube. The necessary pumps for the continuous evacuation of the tube are mounted in the trolley and a Pirani gauge showing the degree of exhaustion is included in the controls, which are mounted on a conveniently sloped ebonite panel in front of the unit.

The camera equipment available includes:

- (a) Debye-Scherrer—Seeman-Bohlin Camera, 5 cms. dia.
- (b) Debye-Scherrer—Seeman-Bohlin Camera, 9 cms. dia.
- (c) Flat-film (back reflection) Camera.
- (d) Cylindrical (preferred orientation) Camera.

Each can be mounted on a slide and each is mechanically rotatable.

The specimens (which may weigh up to 50 lbs.) rest, and are clamped if necessary, on the top of the specimen table, to the underside of which may be attached a camera for transmission photographs. Specimens, such as parts of machinery, which cannot be placed on the specimen table may be examined *in situ*, by tilting the tube and camera equipment to suit the specimen.

A metallurgical microscope for the examination of specimens when set up for X-ray examination can be supplied.

CATALOGUE NUMBERS

E 503.—Dexrae Industrial X-ray Unit complete in Trolley, with X-ray Tube, Transformer, Pumps and all controls, but without Cameras.

E 508.—Flat-Film Camera for E 503 X-ray Unit.

E 509.—Cylindrical (preferred orientation) Camera.

E 510.—Debye-Scherrer and Seeman-Bohlin Camera, 5 cms. diam.

E 511.—Debye-Scherrer and Seeman-Bohlin Camera, 9 cms. diam.

E 527.—Metallurgical Microscope.

THE HILGER X-RAY CRYSTALLOGRAPH

The instruments commonly grouped together under the generic title of X-ray Spectrographs may be conveniently divided into two groups according to their functions; those primarily intended for the analysis of radiations, and employing a known crystal or other grating lattice; those primarily concerned with the study of crystal structure and employing a known type of monochromatic radiation. The latter type we distinguish by the term Crystallograph.

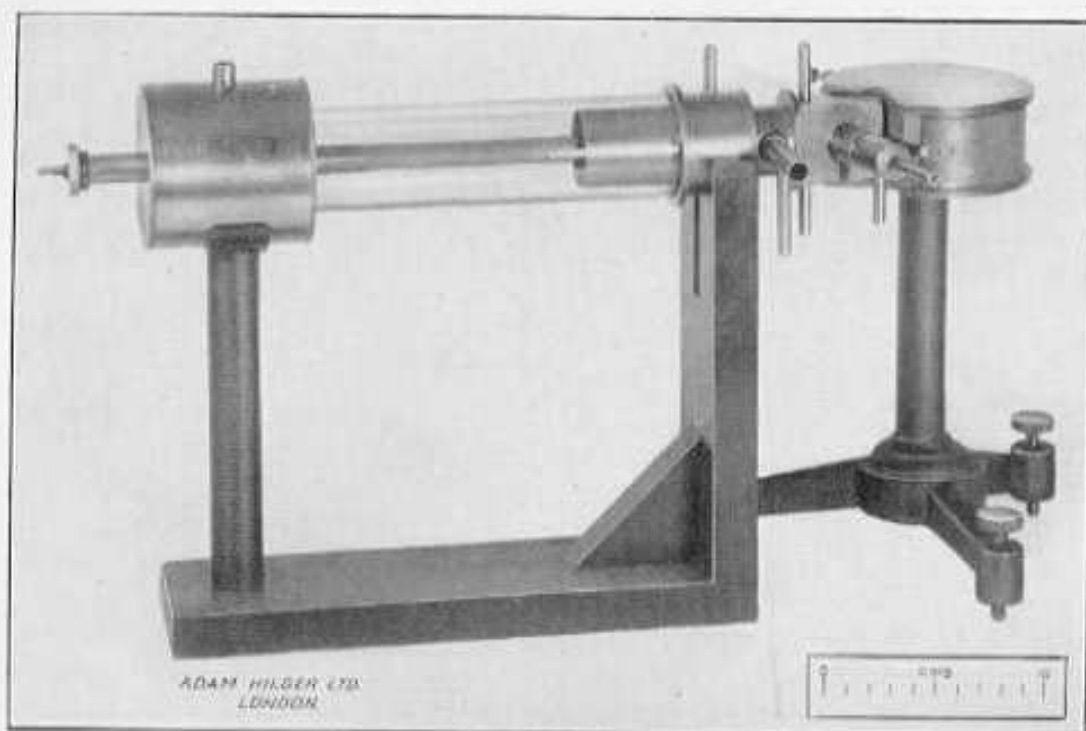

Fig. E 411, F 245

This instrument is so designed that it meets the needs of chemists, metallurgists, geologists and others who desire the analysis of crystalline structure in comparatively short periods of time and with the smallest amount of unfamiliar technique. This is made possible by employing the principle due to Seeman and Bohlin of having the slit, specimen to be examined and the photographic film all disposed on the circumference of the arc of a circle. With this arrangement a "focussing action" takes place from all points of the specimen, thus diminishing the time of exposure required.

By designing the instrument specifically for use with our Shearer X-ray Tube (see Hilger Publication No. 138, "X-ray Tubes and other Accessories") we are able to make provision for its rapid and precise alignment, while a tube of this sort will produce monochromatic illumination when fitted with a metal window suitable for the anticathode in use. A portion of the circular camera is cut away to form a recess fitting the end of the Shearer X-ray tube. One wall of the recess is radial and carries, besides the lead slit jaws, three projecting studs that, in conjunction with a fourth provided with a screw adjustment and lock-nut, serve to locate accurately the X-ray tube window.

One slit jaw is fixed so that its edge coincides with the circumference of the camera while the other is adjustable. At a distance of 1.75 cms. from the slit there is a removable, interchangeable specimen holder, consisting of a glass block so shaped

ADAM HILGER, Ltd., 98 Kings Road, Camden Road, London, N.W. 1

that its face is concave and of a radius corresponding to the " focussing radius " of the instrument. The photographic film (17.5 × 2.5 cms.) is wrapped round the circumference of the camera and secured by a hinged cover.

An important feature of the instrument is a scale that is printed on to the crystallogram. This has been so calculated that when the instrument is used with the filtered radiation from a copper anticathode the scale divisions represent

$$\left[\frac{d_{hkl}}{n} \right] \text{ \AA}$$

where d_{hkl} = the spacing between geometrically like planes.
 n = the order of the spectrum.

hence the interpretation of the crystallograms is rendered comparatively simple.

A complete illustrated description will be sent post free on application.

E 411.—Hilger X-ray Crystallograph.

E 412.—Extra Specimen Holder for Metallic Strips.

(For Shearer X-ray Tube and other accessories suitable for use with this instrument see Hilger Publication No. 138. For photographic film see F 251, page 8 of Hilger Publication No. 138, from each sheet of which eleven pieces of the correct size, 17.5 × 2.5 cms. can be cut.)

F 592.—Shearer X-ray Tube specially fitted with nickel foil window for use with E 411.

THE X-RAY METALLURGICAL CRYSTALLOGRAPH

FOR THE X-RAY EXAMINATION OF THE EFFECTS OF HEAT AND MECHANICAL TREATMENT ON METALS.

This instrument yields information with respect to grain size, crystal orientation, presence of strain, etc., in metals and alloys. Such information has formerly been obtained by instruments employing the Laue method, but the present instrument, which is of the type used by F. Regler (*Zeit. f. Physik*, 71, 371, 1931) is very much simpler, easier to use and more direct in the information which it gives on the above points. The diffraction patterns being obtained directly from the surface of the material, there is no necessity for cutting thin sections, a process during which the existing structure of the material is liable to get distorted.

This crystallograph can cope with specimens of any form, from wires and foils to massive objects.

E 449.—X-Ray Metallurgical Crystallograph, complete as described
 above

E 453.—Sector Disc with Single Aperture.—This disc is so arranged
 that any one quadrant of the film can be exposed ...

E 454.—Sector Disc with Double Aperture.—This disc allows the op-
 posite quadrants of the film to be exposed at any time

**PROFESSOR LABY'S X-RAY SPECTROGRAPH
FOR WAVELENGTH MEASUREMENTS IN THE X-RAY REGION WHICH CAN
BE INVESTIGATED IN AIR**

This instrument is intended for the accurate determination of wavelengths by interpolation from accepted standard lines. It is suitable for the identification and determination of the characteristic emissions of elements and thus for X-ray spectrum analysis.

The X-ray beam, suitably defined by two slits, falls on the surface of the standard crystal which is in uniform angular oscillation over the selected range. The beams reflected from the crystal at the appropriate angles are received on a photographic film. In order that the Bragg focussing condition may be satisfied, the film is bent into the arc of a circle whose centre coincides with the axis of oscillation of the crystal and on whose circumference the first slit, acting as source of X-rays, lies. The photographic film is protected from scattered radiation by a rotating lead screen placed immediately in front of the film holder, and geared to the oscillating mechanism so as to travel with double the angular velocity of the crystal. A narrow aperture is provided in the screen so as to allow the beam selectively reflected at the crystal surface according to Bragg's Law to fall on the film. The wavelengths of unknown lines are determined by interpolation from accurately known standard lines registered on the same film under the same conditions.

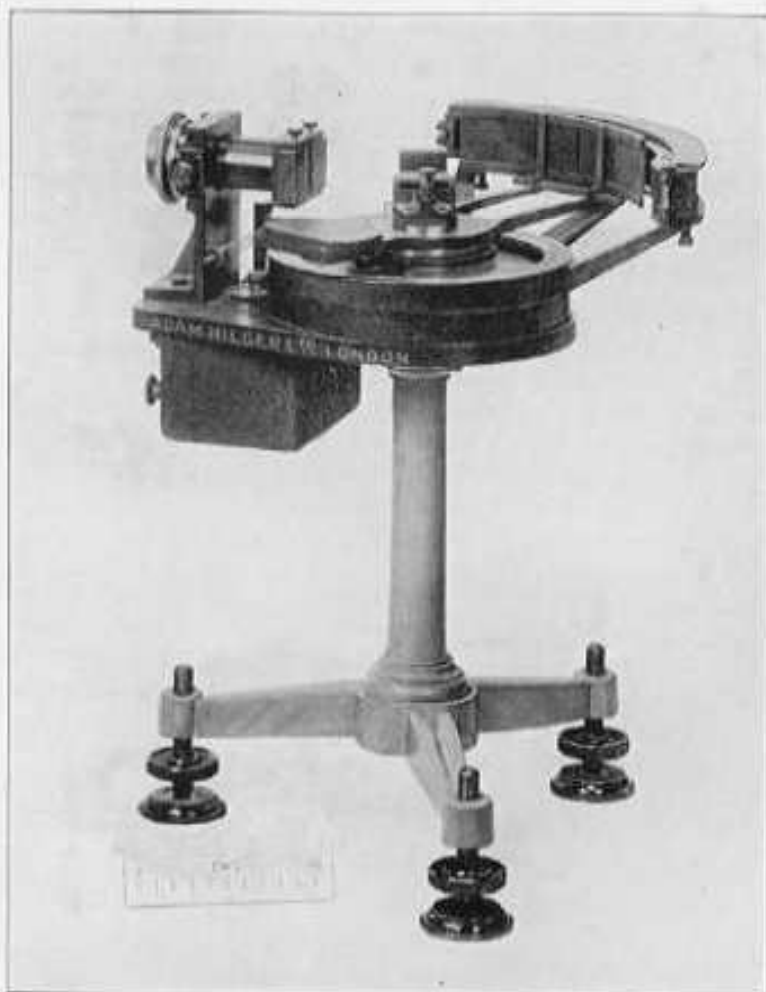

Fig. E 330.

The spectrograph is mounted on a tripod stand provided with levelling screws and supporting a horizontal plate carrying the crystal oscillating mechanism and the remainder of the apparatus. The motor spindle carries a cardioid cam which imparts a uniform oscillation to the crystal table and moving screen by means of a lever and a set of permanently meshed gears. Suitable cams are supplied to give oscillating motions of about 5° , 10° , or 15° . The table and screen are mounted on ball bearings.

The slit system is mounted on a carrier which can be moved in a direction perpendicular to the line joining the slits. The first slit may also be rotated about a horizontal axis. Both are of the symmetrical opening type with gold jaws reinforced with lead and are mounted at a distance of 15 cms. from the axis of rotation of the crystal. The movements controlling their widths are graduated in thousandths of an inch.

Circular scales determine the positions of the film holder, the crystal table and the lead screen. The crystal mount, which has thick lead wings, is secured down to a slide on the table, across which it can be moved by an adjusting screw working against springs. A similar movement is fitted for tilting the mount.

The moving lead screen, 16.5 cms. long, 0.1 cm. thick, with central aperture 0.2 cms. wide, is carried on a frame which fits over a ring round the crystal table. Its position is read from the scale engraved on this ring.

The film holder is in the form of a quadrant of a circle 15 cms. in radius and is mounted concentrically with the crystal table. As the first slit is also 15 cms. distant from the centre of oscillation of the crystal the Bragg focus condition is fulfilled along the length of the film holder. The front of the film holder is in the form of a hinged frame which clamps the film against the cylindrical surface. The complete film holder is attached to its mount by four milled headed bolts. The mount is permanently attached to a ring fitting round the outside of the larger scale on which its position is read.

The exposure necessary depends on the following factors: (a) Source employed; (b) Wavelength it is desired to record; (c) The crystal used; (d) The angular divergence of the beam. For wavelengths not longer than 2 Å reflected from rock-salt or calcite crystals with good reflecting surfaces not less than 1.3 cm. wide, and using a beam sufficiently divergent to fill the crystal, exposures of about one hour should be adequate. For spectrum analysis with very small quantities longer exposures are required. The exposure also increases rapidly with wavelength beyond 2 Å.

With a good crystal and a slit width of $.001''$ the accuracy has been found to be $\pm .0001$ Å (in the region 0.5–1.6 Å) when using the method of interpolation from standard lines in the vicinity.

Although primarily intended for X-ray spectrographic work the instrument can be used for powder crystal analysis by removing the lead screen and crystal mount. It can be recommended for such work only when high accuracy irrespective of time of exposure is required, for owing to the long air path in the instrument (30 cms.), very long exposures would be required.

E 330.—Professor Laby's X-ray Spectrograph, complete as described above.

For use with the above spectrograph a double crystal holder can be supplied. By means of this accessory two crystals may be used at once with different angles of incidence. The angular displacement is shown on an engraved arc.

E 416.—Double Crystal Holder for use with Laby X-ray Spectrograph.

DR. MÜLLER'S IMPROVED X-RAY SPECTROGRAPHS

FOR PHYSICAL, CHEMICAL, METALLURGICAL, CRYSTALLOGRAPHIC AND RADIOGRAPHIC LABORATORIES, AND FOR THE GENERAL STUDY OF X-RAYS

Fully illustrated descriptive booklet post free on application—Hilger Publication No. 58.

Dr. Müller's X-ray spectrograph was the first complete apparatus to be put on the market which was capable of undertaking most of the better known photographic methods of X-ray crystallography and spectrography.

The latest model is capable of being used for any of the principal methods of X-ray spectrography and crystallography in which photographic recording is made use of and in addition can be employed as an optical crystal goniometer.

It is suitable for X-ray spectroscopic work in that region of wavelengths where air absorption is not high.

The number of moving parts is kept to a minimum so that, as a consequence, the instrument has considerable mechanical rigidity despite its moderate weight and size.

In designing it due regard has been paid to the peculiar requirements of an instrument to be used with X-ray apparatus, both as regards constructional details and materials. Recourse to kinematical principles of design ensures the interchangeability of accessory parts in a simple and accurate manner, avoiding the necessity of frequent adjustments. The extensive use of stainless steel overcomes tendencies to corrosion of important scales and circles in the highly active atmosphere in the immediate neighbourhood of X-ray apparatus; a matter which does not always receive the attention it deserves.

GENERAL DESCRIPTION OF CONSTRUCTION

The instrument is made in two forms whose main constructional details are closely similar, since the variations consist chiefly of additions to the simpler model. The simpler model has no goniometer, telescope, collimator, or the special camera and plateholder that necessarily accompany these.

Both instruments are built up (see Fig. E 404a) on a rectangular box-shaped casting containing a powerful clockwork motor, and standing upon levelling screws (16) whose ebonite tops minimise the chances of shock, should the apparatus become charged in use. The motor, which is wound with the key (18), can be started and stopped by means of a brake of which the ebonite disc (24) is the handle. A substantial clamp (13) is provided for fitting either a support for accessories or an optical collimator.

The main triangular section bar (1) upon which the plateholders, slit systems, etc., are supported, is mounted upon a casting (12), a Y-shaped extension (7) of which provides two of the three kinematical points of support for the circular cameras.

A stainless steel divided circle (2) is mounted upon a hollow spindle of standard internal taper, passing through bearings in the casting (12). This circle is divided every degree and can be read by means of a vernier to ten minutes ($10'$) of arc.

The axis of the divided circle carries a lever with a roller (26), which is held by an adjustable spiral spring in contact with any one of a series of cams which may be mounted on the motor spindle (27). In the case of the Goniometer Model continuous rotation of the goniometer and specimen are obtained by means of a gear train consisting of a pair of bevel wheels, and worm and worm wheel which can be disconnected at will by moving a bracket along a slide.

The various accessory parts which fit on this main base will be found in the following description of the two instruments.

ADAM HILGER, Ltd., 98 Kings Road, Camden Road, London, N.W. 1



Fig. E 404a

Dr. Müller's X-ray Goniometer Spectrograph, arranged for X-ray Spectrography.

Accessories included in Dr. Müller's Improved X-ray Spectrograph Catalogue Number E 403:

For X-ray Spectrography, when the instrument is usually set up as shown in Fig. E 404a, the following parts are provided. A slit system mounted with screw adjustment for position. The width is set by means of feeler gauges, and the height can be exposed in three separate portions with the aid of diaphragms supplied. The crystal mount (3) fits the hollow, tapered, centre of the circle (2) by means of a standard taper spindle to which it is attached with screw adjustments. The plate holder takes plates $4\frac{3}{4} \times \frac{3}{4}$ ", and can be set at any desired position on the main bar (1). It has a movable screen in front, which is used in conjunction with the slit diaphragms when comparison spectra are required. There are also gauge plates, pins, and a steel ruler for setting the relative positions of the slit, the crystal, and the plate.

For the X-ray Crystallography of Powders.—A nest of three circular cameras is provided, which permits the selection of a radius of curvature suitable to the problem

ADAM HILGER, Ltd., 98 Kings Road, Camden Road, London, N.W. 1

of the moment. This triple camera is located by a "hole-slot-plane" type of fitting, and is used in conjunction with the same slit system as the above. A pin mount for the powder and a mount for wires and fibres are also supplied on standard taper fittings corresponding with the centre of the circle. A rod and clamp with a little platform to which such accessory apparatus as thermometers, electric heaters, etc., can be secured is provided, and fits the clamp (13) on the side of the body.

E 403.—Dr. Müller's Improved X-ray Spectrograph with all accessories necessary for the Spectrographic and Powder Crystallographic methods as described above. Complete in well-made mahogany case with lock and key.

Accessories included in Dr. Müller's Improved X-ray Goniometer Spectrograph, Catalogue Number E 404:

All the apparatus listed above is included in this instrument together with the following.

For taking Laue Photographs.—An X-ray collimator with a series of drilled plugs whereby the size of the X-ray pencil can be regulated. A plateholder, taking plates $4\frac{1}{4}'' \times 3\frac{1}{4}''$, fitting a mount with kinematical locating devices. A stainless steel two-circle goniometer. This last is the most important of the accessory parts of the E 404. It is very carefully designed to obtain the greatest possible accuracy for its size. Every part is made of stainless steel. The circles are engraved to each degree, and can be read by verniers to $10'$ ($\frac{1}{6}''$). In the standard goniometer supplied there is a range of motion of 120° in two directions at right angles to one another. Another goniometer having a maximum range of 15° can be supplied if desired. The accuracy of the goniometers is such that no greater departure of the crystal mount from a fixed point than ± 0.1 mm. is permitted.

For setting up the Crystal and for use as a Crystal Goniometer.—The two-circle goniometer above is used, and a special telescope in a mount having precise but simple adjustments is used in conjunction with a simple optical collimator. The telescope mount, like the plateholder mounts, slides on the main triangular bar. It has a raising and lowering motion and screw movements for rotating the telescope in two planes over small angles. The telescope has an auxiliary lens whose use converts it to a low-power microscope. The collimator is attached to a rod and clamped to the main body of the instrument. It is furnished with a Websky signal and 4v. lamp. A simple tangent screw slow motion on the goniometer spindle gives fine adjustment of the crystal position about a vertical axis.

For Revolving Crystal Photographs the crystal can be mounted on the goniometer and slowly revolved by a worm and bevel gear train set in motion by the clockwork motor. The pattern can be recorded, if desired, on a flat plate using the $4\frac{1}{4}'' \times 3\frac{1}{4}''$ plateholder mentioned above, or on a film held in a cylindrical camera. A large double cylindrical camera is provided so that the user has the choice of two radii.

E 404.—Dr. Müller's Improved Goniometer X-ray Spectrograph with all accessories necessary for the methods of X-ray spectrography and crystallography and for use as an optical crystal goniometer as described above with 60° goniometer only. Complete in two well-made mahogany cases with locks and keys.

E 444.—Dr. Müller's Improved Goniometer X-ray Spectrograph. As above, but with 15° goniometer only.

E 435.—Extra 15° Goniometer for E 404 above.

The foregoing descriptions are only brief summaries of the important points of this unique instrument. Complete details will be found in Hilger Publication No. 58.

ADAM HILGER, Ltd., 98 Kings Road, Camden Road, London, N.W. 1

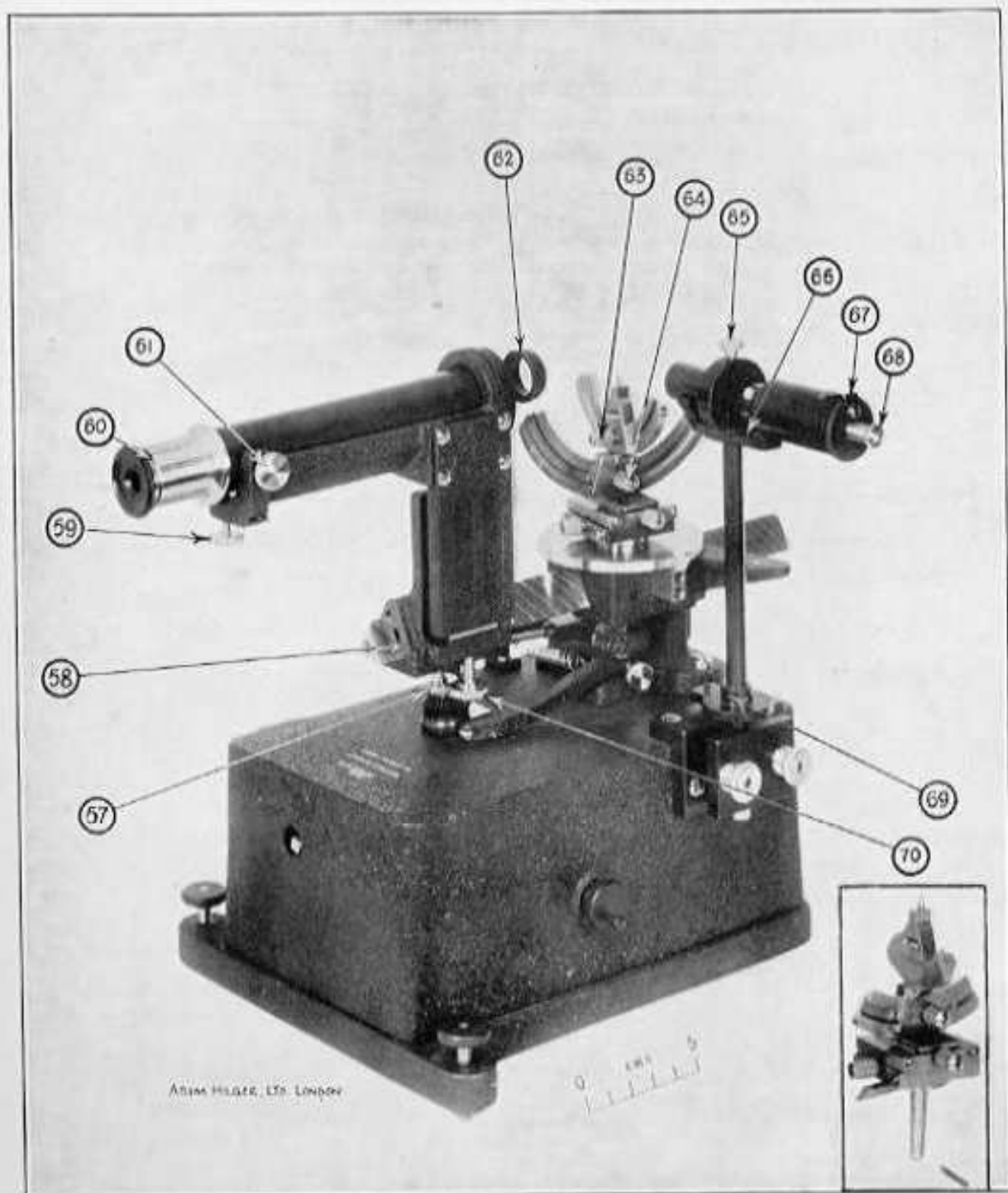

Fig. E 404f

Dr. Müller's X-ray Goniometer Spectrograph with Telescope and Optical Collimator for setting up crystals
Inset: 15° Goniometer E 435.

VACUUM BOX FOR MÜLLER X-RAY SPECTROGRAPH

In the investigation of organic substances, such as woollen fibres, or other materials comprising light atoms only, the amount of scattering of X-rays by the gases of the atmosphere becomes comparable with that from the material itself and hence greatly reduces contrast in the X-ray photograph. It is desirable in such cases to eliminate the scattering and a metal box which can be evacuated has been designed to take the E 404 Müller X-ray Goniometer Spectrograph. The box is provided with an aluminium window, similar to that of the Shearer tube, and can be placed quite close to the latter.

E 387.—Vacuum Box for Müller X-ray Goniometer Spectrograph.

EQUIPMENT FOR THE PRODUCTION OF X-RAYS

SUITABLE FOR USE WITH DR. MÜLLER'S X-RAY
GONIOMETER SPECTROGRAPH, ETC.

including

All-Metal X-Ray Tubes, Shearer X-Ray Tubes, Pumps,
Photographic Materials, Transformers, and Sundries
can be supplied, and are fully described in Hilger Publi-
cation, No. 138, "X-Ray Tubes and other accessories,"
which will be sent post free on application.

**CATALOGUE NUMBERS OF INSTRUMENTS OF SERIES E
WHICH ARE NOT FULLY DESCRIBED IN
THIS CATALOGUE E**

E 464.—The Finch Electron Diffraction Apparatus.

E 464.—The Finch Electron Diffraction Camera for Gases.

E 466.—Extra Specimen Holder Section for Gases for E 464-5.

E 467.—Extra Specimen Holder Section for Thin Films for E 464-5.

(The above are made by the Cambridge Instrument Company, London and Cambridge ; they are fully described in Hilger Publication No. 210).

E 507.—One pair of Hinges for use with two accessory bars E 481.

E 513.—Extra Long Accessory Bar.

E 514.—Adaptor for holding two Accessory Bars at right angles.

E 524.—Holiday Plate Moving Cam. A device for the rapid photography of fine detail in absorption spectra. Full particulars on request.

July, 1937.

INDEX TO CATALOGUE E

| ITEM. | CAT. NOS. | PAGE. | ITEM. | CAT. NOS. | PAGE. |
|--|-------------------------------|---------|---|--------------|-------|
| Astronomical Spectrographs - (see also Cat. G) | various | E 28 | Grating Spectrographs (See Interchangeable Spectro- graphs) | — | — |
| Automatic Large Spectrographs | | | do. Eagle Mounting | E 18, E 74 | 38 |
| Quartz | E 492 | 3-5 | Grating Stigmatic | E 367, E 49 | 39 |
| " Quartz and Glass | E 478 | 5-6 | " Vacuum one metre . . . | E 368 | 40-41 |
| " Glass | E 493 | 6 | " " two metre | E 422 | 42 |
| Bar, Standard Accessory . . . | E 481-2 | 12 | " " Grazing inci- dence | E 423, E 525 | 42-43 |
| " " Additions | E 507, etc. | 58 | Infra-Red Glass Prism etc. for Medium Spectra | E 473 | 14 |
| Compound D.V. Dispensor . . | E 522 | 25-27 | do. Spectrograph | E 474 | 15 |
| Condensers for Large Spectro- graph | E 371, E 475, E 402, E 476 | 9 | Interchangeable Spectrographs Intermediate Quartz Spectro- graphs (F ₀ 38 cms.) | — | 29-37 |
| Dark slides for Large Spectro- graphs | E 468, E 469 | 10 | Large Spectrographs (F ₀ 170 cms.) | E 486 | 16 |
| " " Medium Spectro- graphs | E 470/1, E 501/2 | 14 | " Automatic, Quartz | E 492 | 3-5 |
| " " Small Spectro- graphs | E 472 | 18 | " " Quartz and Glass | E 478 | 5-6 |
| " " Interchangeable Spectrographs | various | 36 | " " Glass | E 493 | 6 |
| Direct Vision Dispensor . . . | E 522 | 25-27 | " All-metal, Quartz | E 383, E 384 | 8-9 |
| Discharge Tube Vac. Gauge . . | F 353 | 47 | " " Glass | E 401 | 10 |
| Electron Diffraction Appara- tus, Finch | E 464, etc. | 58 | " Scales for | E 384, E 385 | 9 |
| Fluorescent Screen in Mount . . | E 440 | 18 | " Condensers for | E 371 etc. | 9 |
| Fluorescence Spectrograph . . | E 350, etc. | 40 | " Plateholders for | E 468, E 469 | 10 |
| Glass Prism and Lenses for Large Spectrograph | E 52 | 10 | " Glass Prism for | E 52 | 10 |
| for Medium Spectrograph . . . | E 332, E 408, E 473 | 14 | Large Aperture Spectrographs | | |
| for f/4 Spectrograph | E 443 | 21 | F/7 Glass | E 349 | 22 |
| for Interchangeable Spectro- graph | E 230-3-6 E 239-42-45 | 36 | f/5-7 Two-prism Glass | E 328 | 23 |
| Glass Spectrographs | | | f/4 Glass | E 517 | 20-21 |
| Large | E 391, E 401, E 493 | 10 | f/4 Quartz | E 518 | 20-21 |
| Medium | E 494-5 E 496 | 15 | f/4 Extra Optic for | E 442, E 443 | 21 |
| f/7 | E 349 | 22 | f/2 Quartz | E 505 | 21 |
| Two Prism f/5-7 | E 328 | 23 | f/2 Glass | E 506 | 21 |
| F/4 | E 518 | 20-21 | f/1-5 Two-prism Glass | E 523 | 24 |
| Two-prism F/1-5 | E 523 | 24 | f/1 Extra Large Aperture . . | E 424, E 426 | 25 |
| Extra Large Aperture F/1 . . | E 424, E 426 | 25 | Liquid Prism (Compound Dis- persor) | E 522 | 25-26 |
| F/2 | E 506 | 21 | Littrow Spectrographs (See also Large (F ₀ 170 cms.)- (See also Interchangeable Spectrographs). | — | — |
| Littrow of High Dispersion . . | E 347 | 27 | 25 ft. focus Glass | E 347 | 27 |
| Infra-Red | E 474 | 15 | 25 ft. focus Quartz | E 348 | 27 |
| (See also Interchangeable Spectrographs and Large Spectrographs) | — | — | Glass, F/7 | E 349 | 22 |
| | | | Medium Spectrographs (F ₀ 60 cms.) | | |
| | | | Quartz, Barfit Standard . . . | E 488 | 13-14 |
| | | | Quartz Flat-Field | E 498 | 11-12 |
| | | | Glass | E 494, E 495 | 15 |
| | | | Glass and Quartz | E 496 | 15 |

INDEX—continued.

| ITEM. | CAT. NOS. | PAGE. | ITEM. | CAT. NOS. | PAGE. |
|-------------------------------------|---------------|-------|------------------------------------|-------------------------------|-------|
| Microscope for X-ray Unit | E 527 | E 49 | Trolley Stand | E 302, E 303, E 304 | E 36 |
| Plate-holders (Dark Slides) | | | Vacuum Arc Lamps | F 280, F 596, F 662 | 46-47 |
| for Large Spectrographs | E 468, E 469 | 10 | Vacuum Spectrographs | | |
| for Medium Spectrographs | E 470, E 471 | 14 | Grating 1 metre | E 308 | 40-41 |
| for Small Spectrograph | E 472 | 18 | " 2 metre | E 422 | 42 |
| for Interchangeable Spectro- | | | " grazing incidence | E 423, E 525 | 42-43 |
| graphs | various | 36 | Fluorite with W.L. scale | E 419 | 43-44 |
| Plates, Schumann | various | 47 | Fluorite or Quartz | E 489, E 490, E 491 | 44-46 |
| (See also Catalogue F.) | | | X-ray Crystallographs | | |
| Raman Effect, Spectrographs | | | Dexrae Unit | E 503, etc. | 48-49 |
| for (F/4) | E 517, E 518, | 20-21 | Hilger | E 411, etc. | 50-51 |
| for (F/2) | E 505, E 506 | 21 | Metallurgical | E 449 | 51 |
| Small Quartz Spectrograph | | | Sector Disc for | E 453, E 454 | 51 |
| (F ₀ 20 cms.) | E 484 | 17-18 | X-ray Spectrographs | | |
| do. plateholders for | E 472 | 18 | Laby | E 330 | 52-53 |
| Table of dispersions | — | 19 | Müller | E 403, E 404, E 444, E 435 | 54-57 |

ADAM HILGER, LTD.

WORKS, LABORATORIES AND SHOWROOMS:

98 Kings Road, Camden Road, London, N.W. 1

Telegraphic Address—"Sphericity, 'Phone, London."

Telephone—Gulliver—5428.

Cable Address—"Sphericity, London."



inv. m. 13520/BAOA

PRICE SHEET

CATALOGUE E JULY, 1937

(JULY 1937 EDITION)

Catalogue Numbers:—We recommend our customers to make use of the Catalogue Numbers when making enquiries or sending orders. They will be found particularly useful when cabling.

Prices:—Prices are nett for delivery at our Works, and packing is extra. Where no price is given and the catalogue number is followed by * the apparatus in question will be the subject of a special quotation. All prices are subject to confirmation upon acceptance of order.

We shall be very pleased at any time to quote prices, including packing and delivery f.o.b. London, or delivery to any foreign port or railway station.

Cheques should be crossed:—"Midland Bank, Ltd."

Page Index:—This refers to the catalogue of the date indicated. Earlier or later editions may vary slightly in their paging.

VOLTAGE. Important. When ordering any apparatus that is to be connected to the electric mains please include full information as to voltage, frequency, etc.

CATALOGUE E

| Catalogue Number | Price | | | Catalogue Page | Catalogue Number | Price | | | Catalogue Page |
|------------------|-------|----|----|----------------|------------------|-------|----|----|------------------|
| | £ | s. | d. | | | £ | s. | d. | |
| E 18* | | | | E 38 | E 350 | 283 | 0 | 0 | E 40 |
| E 49 | 498 | 15 | 0 | E 39 | E 352* | | | | 40 |
| E 52 | 68 | 5 | 0 | E 10 | E 359 | 31 | 0 | 0 | 28 |
| E 74* | | | | E 38 | E 360 | 38 | 0 | 0 | 28 |
| E 178 | 261 | 0 | 0 | E 36 | E 367 | 290 | 0 | 0 | 39 |
| E 179 | 300 | 0 | 0 | E 36 | E 368 | 275 | 0 | 0 | 41 |
| E 181 | 318 | 0 | 0 | E 36 | E 371 | 8 | 0 | 0 | 9 |
| E 182 | 344 | 0 | 0 | E 36 | E 375 | 5 | 10 | 0 | 37 |
| E 184 | 401 | 0 | 0 | E 36 | E 376 | 6 | 10 | 0 | 37 |
| E 185 | 419 | 0 | 0 | E 36 | E 377 | 7 | 15 | 0 | 37 |
| E 212 | 55 | 0 | 0 | E 36 | E 378 | 0 | 17 | 6 | 37 |
| E 215 | 58 | 0 | 0 | E 36 | E 383 | 327 | 0 | 0 | 8 |
| E 218 | 92 | 0 | 0 | E 36 | E 384 | 347 | 0 | 0 | 9 |
| E 221 | 68 | 0 | 0 | E 36 | E 385 | 20 | 0 | 0 | 9 |
| E 224 | 132 | 0 | 0 | E 36 | E 387* | | | | 57 |
| E 227 | 132 | 0 | 0 | E 36 | E 391 | 300 | 5 | 0 | 10 |
| E 230 | 56 | 0 | 0 | E 36 | E 401 | 320 | 5 | 0 | 10 |
| E 233 | 78 | 0 | 0 | E 36 | E 402 | 10 | 10 | 0 | 9 |
| E 236 | 135 | 0 | 0 | E 36 | E 403* | | | | 56 |
| E 239 | 63 | 0 | 0 | E 36 | E 404 | 180 | 0 | 0 | 56 |
| E 242 | 98 | 0 | 0 | E 36 | E 408 | 80 | 15 | 0 | 14 |
| E 245 | 160 | 0 | 0 | E 36 | E 411 | 36 | 0 | 0 | 51 |
| E 248 | 55 | 0 | 0 | E 36 | E 412 | 5 | 0 | 0 | 51 |
| E 251 | 58 | 0 | 0 | E 36 | E 416 | 15 | 0 | 0 | 53 |
| E 254 | 92 | 0 | 0 | E 36 | E 419 | 350 | 0 | 0 | 44 |
| E 257 | 25 | 0 | 0 | E 36 | E 422 | 440 | 0 | 0 | 42 |
| E 260 | 42 | 0 | 0 | E 36 | E 423 | 735 | 0 | 0 | 43 |
| E 263 | 67 | 0 | 0 | E 36 | E 424* | | | | 25 |
| E 267 | 3 | 5 | 0 | E 36 | E 426* | | | | 25 |
| E 269 | 3 | 5 | 0 | E 36 | E 429* | | | | 25 |
| E 271 | 3 | 0 | 0 | E 36 | E 430* | | | | 25 |
| E 273 | 3 | 5 | 0 | E 36 | E 431* | | | | 25 |
| E 275 | 3 | 5 | 0 | E 36 | E 435 | 35 | 0 | 0 | 56 |
| E 277 | 3 | 0 | 0 | E 36 | E 440 | 12 | 0 | 0 | 18 |
| E 279 | 3 | 0 | 0 | E 36 | E 442 | 77 | 0 | 0 | 21 |
| E 281 | 3 | 0 | 0 | E 36 | E 443 | 65 | 0 | 0 | 21 |
| E 283 | 3 | 0 | 0 | E 36 | E 444 | 180 | 0 | 0 | 56 |
| E 285 | 3 | 0 | 0 | E 36 | E 449 | 46 | 0 | 0 | 52 |
| E 287 | 3 | 0 | 0 | E 36 | E 453* | | | | 52 |
| E 289 | 3 | 0 | 0 | E 36 | E 454 | 17 | 10 | 0 | 52 |
| E 291 | 3 | 0 | 0 | E 36 | E 464 | 330 | 0 | 0 | 58 |
| E 293 | 3 | 0 | 0 | E 36 | E 465 | 420 | 0 | 0 | 58 |
| E 295 | 3 | 0 | 0 | E 36 | E 466 | 195 | 0 | 0 | 58 |
| E 302 | 20 | 0 | 0 | E 36 | E 467 | 105 | 0 | 0 | 58 |
| E 303 | 20 | 0 | 0 | E 36 | E 468 | 12 | 10 | 0 | 10 |
| E 304 | 30 | 0 | 0 | E 36 | E 469 | 12 | 10 | 0 | 10 |
| E 328 | 400 | 0 | 0 | E 23 | E 470 | 12 | 10 | 0 | 14 |
| E 329 | 194 | 0 | 0 | E 28 | E 471 | 12 | 10 | 0 | 14 |
| E 330* | | | | E 53 | E 472 | 8 | 10 | 0 | 18 |
| E 332 | 60 | 0 | 0 | E 14 | E 473* | | | | 14 |
| E 337 | 184 | 0 | 0 | E 28 | E 474 | 220 | 0 | 0 | 15 |
| E 338 | 252 | 0 | 0 | E 28 | E 475 | 4 | 10 | 0 | 9 |
| E 339 | 242 | 0 | 0 | E 28 | E 476 | 2 | 0 | 0 | 9 |
| E 340 | 450 | 0 | 0 | E 28 | E 478 | 575 | 0 | 0 | 6 |
| E 341 | 8 | 0 | 0 | E 28 | E 481 | 7 | 15 | 0 | 5, 6, 14, 16, 18 |
| E 343 | 9 | 0 | 0 | E 28 | E 482 | 6 | 15 | 0 | 5, 6, 14, 16, 18 |
| E 344 | 7 | 10 | 0 | E 28 | E 484 | 85 | 0 | 0 | 18 |
| E 345 | 284 | 0 | 0 | E 28 | E 486 | 150 | 0 | 0 | 16 |
| E 346 | 298 | 0 | 0 | E 28 | E 488 | 204 | 0 | 0 | 14 |
| E 347* | | | | E 27 | E 489 | 117 | 0 | 0 | 46 |
| E 348* | | | | E 27 | E 490 | 48 | 0 | 0 | 46 |
| E 349 | 570 | 0 | 0 | E 22 | E 491 | 28 | 0 | 0 | 46 |

CATALOGUE E

| Catalogue Number | Price | | | Catalogue Page | Catalogue Number | Price | | | Catalogue Page |
|------------------|-------|----|----|----------------|------------------|-------|----|----|----------------|
| | £ | s. | d. | | | £ | s. | d. | |
| E 492 . . . | 425 | 0 | 0 | E 5 | E 509 . . . | 13 | 0 | 0 | E 48 |
| E 493 . . . | 425 | 0 | 0 | 6 | E 510 . . . | 25 | 0 | 0 | 48 |
| E 494 . . . | 182 | 0 | 0 | 15 | E 511 . . . | 25 | 0 | 0 | 48 |
| E 495 . . . | 205 | 0 | 0 | 15 | E 513 . . . | 12 | 15 | 0 | 58 |
| E 496 . . . | 291 | 0 | 0 | 15 | E 514 . . . | 4 | 0 | 0 | 58 |
| E 498 . . . | 231 | 0 | 0 | 12 | E 517 . . . | 200 | 0 | 0 | 21 |
| E 501 . . . | 12 | 10 | 0 | 14 | E 518 . . . | 188 | 0 | 0 | 21 |
| E 502 . . . | 12 | 10 | 0 | 14 | E 522 . . . | 78 | 0 | 0 | 26 |
| E 503 . . . | 273 | 0 | 0 | 48 | E 523* . . . | | | | 24 |
| E 505 . . . | 456 | 0 | 0 | 21 | E 524* . . . | | | | 58 |
| E 506 . . . | 362 | 0 | 0 | 21 | E 525* . . . | | | | 43 |
| E 507* . . . | | | | 58 | E 526 . . . | 195 | 0 | 0 | 15 |
| E 508 . . . | 12 | 0 | 0 | 48 | E 527* . . . | | | | 48 |

| | | | | | | | | | |
|-------------------|----|----|---|------|--------------------|----|----|---|------|
| F 94 per doz. . . | 0 | 19 | 0 | E 47 | F 596 . . . | 40 | 0 | 0 | E 47 |
| F 280 . . . | 25 | 0 | 0 | 46 | F 597 per doz. . . | 2 | 4 | 3 | 47 |
| F 353 . . . | 1 | 0 | 0 | 47 | F 662* . . . | | | | 47 |
| F 370 pair . . . | 1 | 14 | 6 | 40 | F 677 per doz. . . | 3 | 15 | 0 | 47 |
| F 592 . . . | 21 | 0 | 0 | 51 | F 694 per doz. . . | 2 | 4 | 3 | 47 |

TERMS OF BUSINESS

Cash with order, or good London references.

Credit accounts are payable during the month following date of delivery.

FOREIGN ORDERS should be accompanied by a remittance, or credit with an English Bank or first-class Firm, who will pay on presentation of invoice. This condition does not apply in the case of official orders from recognised Colleges and Scientific Institutions.

The prices are for net cash at our Works, and in no case subject to discount.

INSURANCE.—See Below

CONDITIONS DE FOURNITURE

Païement avec la commande, ou bonnes références à Londres.

Les commandes de l'étranger doivent être accompagnées de leur montant ou créditées sur une banque anglaise ou une maison de premier ordre, qui paiera sur présentation de la facture. Cette condition ne s'applique pas aux commandes officielles des Universités ou organismes scientifiques reconnus.

Les prix s'entendent nets à nos usines, et ne sont en aucun cas susceptibles de remise.

LIEFERUNGSBEDINGUNGEN

Die Preise verstehen sich gegen Kasse; andernfalls sind Prima-Referenzen in London aufzugeben.

Bestellungen aus dem Auslande ist der entsprechende Betrag beizufügen oder bei einer englischen Bank respektive Firma ersten Ranges sicher zu stellen, wobei Zahlung gegen Präsentation der Faktura zu erfolgen hat. Diese Bestimmung erstreckt sich jedoch nicht auf Staatsinstitute und Behörden.

Die Preise gelten für Kasse ohne jeglichen Abzug.

INLAND ORDERS

The very greatest care is exercised in packing, which is charged at cost price, and ADAM HILGER, Ltd., cannot hold themselves responsible for injuries, which should be claimed for from the carrier. Cases should always be examined on arrival in the presence of the carman for any external signs of damage and his recognition of any such damage obtained.

Inland cases returned carriage paid and in good condition within fourteen days will be credited in full.

INSURANCE IN TRANSIT

Unless we receive specific instructions to the contrary we usually insure export consignments against "all risks including breakage of glass, crystal and the like." The cost of this insurance varies from fifteen shillings to twenty shillings per £100 according to the distance.

No Claims under our Insurance Policy can be entertained unless we are furnished with the Certificate mentioned below.

If, on opening the case, any part of the apparatus is found to be damaged, a Certificate of the extent of the damage should be obtained from Lloyd's Agent in the city of arrival. Should there be any difficulty in communicating with Lloyd's Agent, a Certificate should be obtained from a responsible third party. This Certificate should be sent to ADAM HILGER, Ltd., with a covering letter.

ASSURANCE CONTRE LES RISQUES DE TRANSPORT

Sauf entente préalable, les expéditions sont assurées par nos soins contre tous risques, y compris le bris de verre, cristal, etc. La prime d'assurance est variable entre 15s. 0d. et £1 pour £100, suivant la distance.

Il ne sera tenu compte d'aucune réclamation non accompagnée du Certificat mentionné ci-dessous.

En cas de casse constatée à l'ouverture des caisses, il incombe au destinataire de provoquer une expertise en s'adressant à l'agent accrédité de Lloyd's ou, à défaut, à une tierce personne compétente. Le rapport de cet agent constatant l'importance de la casse, accompagné d'une lettre du destinataire, doit être adressé à la Maison ADAM HILGER, Ltd.

TRANSPORTVERSICHERUNG

Mangels besonderer abweichender Anweisungen versichern wir gewöhnlich alle Sendungen nach dem Auslande gegen "alle Gefahren einschliesslich Bruch von Glas, Kristall, u. dgl." Die Gebühren für diese Versicherung betragen 15 bis 20 shillings per £100, je nach der Entfernung.

Reklamationen unter unserer Versicherungspolice können nicht anerkannt werden mangels der unten erwähnten Bescheinigung.

Falls bei Öffnung der Paekkte irgend ein Teil des Apparates sich als beschädigt erweist, so ist eine Bescheinigung über die Grösse des Schadens von dem Lloyd'schen Vertreter der betreffenden Stadt zu erwirken. Sollte kein solcher Vertreter zugänglich sein, so ist die erforderliche Bescheinigung von einer dritten verantwortlichen Person auszustellen. Diese Bescheinigung ist dann der Firma ADAM HILGER, LTD., nebst einem Begleitschreiben zuzustellen.

ADAM HILGER, LTD.,

WORKS, LABORATORIES AND SHOWROOMS

98 KINGS ROAD, CAMDEN ROAD, LONDON, N.W.1

Telephone No.: GULLiver 5426

Telegraphic Address: Sphericity, 'Phone, London
(Charged as two words only)

PRINTED IN GREAT BRITAIN

H 1500/1709/7/57

PRICE ALTERATIONS AND ADDITIONS

Incorporating and amending the prices on Sheets Nos. 1 and 2.

All prices are subject to confirmation on receipt of order

CATALOGUE B

| Catalogue Number | Price | | | Catalogue Page | Catalogue Number | Price | | | Catalogue Page |
|------------------|-------|----|----|----------------|------------------|-------|----|----|----------------|
| | £ | s. | d. | | | £ | s. | d. | |
| B 52* | | | | B 11 | B 277* | | | | B 11 |
| B 255* | | | | B 11 | B 278* | | | | B 11 |
| B 256* | | | | B 11 | B 340 | 13 | 10 | 0 | S.B. 241 |

CATALOGUE D

| | | | | | | | | | |
|---------|-----------|----|---|----------|-----------|-----------|----|---|----------|
| D 32 | Withdrawn | | | | D 160 | 115 | 10 | 0 | S.B. 243 |
| D 79* | | | | D 14 | D 163-5 | Withdrawn | | | D 4 |
| D 93* | | | | D 7 | D 167 | 7 | 0 | 0 | S.B. 241 |
| D 105 | 47 | 10 | 0 | D 7 | D 184 | 1 | 12 | 0 | S.B. 241 |
| D 106 | 160 | 0 | 0 | D 12 | D 186 | 79 | 0 | 0 | S.B. 241 |
| D 138-9 | Withdrawn | | | D 4 | D 187 | 79 | 0 | 0 | S.B. 241 |
| D 141-2 | do. | | | D 4 | D 188-192 | Withdrawn | | | D 4 |
| D 144-5 | do. | | | D 4 | D 202 | 38 | 0 | 0 | M 20 |
| D 147-8 | do. | | | D 4 | D 203 | 28 | 0 | 0 | S.B. 241 |
| D 150-1 | do. | | | D 4 | D 206 | 47 | 0 | 0 | S.B. 241 |
| D 158 | 120 | 10 | 0 | S.B. 243 | | | | | |

CATALOGUE E

| | | | | | | | | | |
|--------|-----------|---|-----|-----------|--------|-----------|----|---|------|
| E 44 | Withdrawn | | | | E 442 | 77 | 0 | 0 | E 21 |
| E 179 | 300 | 0 | | E 36 | E 444 | 180 | 0 | 0 | E 56 |
| E 330* | | | | E 53 | E 474 | 220 | 0 | 0 | E 15 |
| E 347* | | | | E 27 | E 478 | 575 | 0 | 0 | E 6 |
| E 348* | | | | E 27 | E 481 | 7 | 15 | 0 | E 5 |
| E 366 | Withdrawn | | | | E 482 | 6 | 15 | 0 | E 5 |
| E 373 | Withdrawn | | | | E 483 | Withdrawn | | | |
| E 379 | Withdrawn | | | | E 484 | 85 | 0 | 0 | E 18 |
| E 386 | Withdrawn | | | | E 486 | 150 | 0 | 0 | E 16 |
| E 387* | | | | E 57 | E 487 | Withdrawn | | | |
| E 392 | Withdrawn | | | | E 493 | 425 | 0 | 0 | E 6 |
| E 395 | Withdrawn | | | | E 494 | 182 | 0 | 0 | E 15 |
| E 396 | Withdrawn | | | | E 495 | 205 | 0 | 0 | E 15 |
| E 399 | Withdrawn | | | | E 497 | Withdrawn | | | |
| E 403* | | | | E 56 | E 498 | 231 | 0 | 0 | E 12 |
| E 404 | 180 | 0 | 0 | E 56 | E 501 | 12 | 10 | 0 | E 14 |
| E 406 | Withdrawn | | | | E 502 | 12 | 10 | 0 | E 14 |
| E 412 | 5 | 0 | 0 | E 51 | E 504 | Withdrawn | | | |
| E 420 | Withdrawn | | see | E 517-518 | E 505 | 456 | 0 | 0 | E 21 |
| E 424* | | | | E 25 | E 506 | 362 | 0 | 0 | E 21 |
| E 426* | | | | E 25 | E 507* | | | | E 58 |
| E 427 | Withdrawn | | | | E 512 | Withdrawn | | | |
| E 429* | | | | E 25 | E 513 | 12 | 15 | 0 | E 58 |
| E 430* | | | | E 25 | E 517 | 200 | 0 | 0 | E 21 |
| E 431* | | | | E 25 | E 518 | 188 | 0 | 0 | E 21 |
| E 432 | Withdrawn | | | | E 522 | 78 | 0 | 0 | E 26 |
| E 435 | 35 | 0 | 0 | E 56 | E 523* | | | | E 24 |
| E 439 | Withdrawn | | see | E 517-518 | E 526 | 195 | 0 | 0 | E 15 |

* Prices quoted on application

CATALOGUE F

| Catalogue Number | Price | | | Catalogue Page | Catalogue Number | Price | | | Catalogue Page |
|------------------|-------|------|----|----------------|------------------|-------|------|----|----------------|
| | £ | s. | d. | | | £ | s. | d. | |
| F 7 | Withd | rawn | | | F 917 | 6 | 10 | 0 | F 57 |
| F 8 | Withd | rawn | | | F 926 | 1 | 10 | 0 | F 10 |
| F 13 | Withd | rawn | | | F 949 pair | 0 | 8 | 0 | F 31 |
| F 43/4 | 8 | 10 | 0 | F 10 | doz. pair | 4 | 4 | 0 | |
| F 289 | 0 | 15 | 0 | F 17 | F 951 to 954 | Withd | rawn | | |
| F 307 | 1 | 15 | 0 | F 26 | F 975 | 0 | 10 | 0 | F 53 |
| F 449 | 17 | 5 | 0 | F 21 | F 977 | 9 | 0 | 0 | F 2 |
| F 450 | 1 | 5 | 0 | F 22 | F 978 | 22 | 0 | 0 | F 7 |
| F 580 | 19 | 5 | 0 | F 21 | F 980 | Withd | rawn | | |
| F 624 pair | 0 | 4 | 0 | F 31 | F 982 | 10 | 10 | 0 | F 46 |
| doz. pair | 2 | 2 | 0 | | F 993 | 7 | 10 | 0 | F 27 |
| F 628 | 0 | 17 | 6 | F 31 | F1023 | 56 | 0 | 0 | F 22 |
| F 642 | 41 | 10 | 0 | F 52 | F1031 | 11 | 0 | 0 | F 19 |
| F 679 | Withd | rawn | | | F1032 | 11 | 0 | 0 | F 19 |
| F 690 | Withd | rawn | | | F1033 | 3 | 0 | 0 | F 46 |
| F 691 | Withd | rawn | | | F1042 | 6 | 10 | 0 | F 17 |
| F 693 pair | 0 | 7 | 6 | F 31 | F1043 | 7 | 2 | 6 | F 17 |
| doz. pair | 4 | 0 | 0 | | F1045 | 7 | 10 | 0 | F 57 |
| F 700 | 22 | 2 | 0 | F 29 | F1053 | 14 | 10 | 0 | F 19 |
| F 737 | 1 | 5 | 0 | F 5 | F1063 | 14 | 10 | 0 | F 19 |
| F 803 pair | 3 | 16 | 0 | F 32 | F1065 | 1 | 10 | 0 | F 19 |
| F 813 | 5 | 12 | 0 | F 45 | F1066 | 3 | 10 | 0 | F 19 |
| F 814 | 0 | 1 | 0 | F 45 | F1067 each | 0 | 2 | 0 | F 32 |
| F 815 | 0 | 1 | 6 | F 45 | dozen | 1 | 1 | 0 | F 32 |
| F 816 | 2 | 7 | 6 | F 45 | F1068 each | 0 | 2 | 0 | F 32 |
| F 818 to 820 | Withd | rawn | | | dozen | 1 | 1 | 0 | |
| F 821 | 30 | 0 | 0 | F 46 | F1083 | 15 | 15 | 0 | F 3 |
| F 856 | With | rawn | | | F1096 100gms. | 0 | 8 | 6 | S.B. 94 |
| F 882 | 56 | 0 | 0 | F 22 | F1100 each | 0 | 15 | 0 | |
| F 890 each | 0 | 7 | 6 | F 31 | | | | | |

CATALOGUE H

| | | | | | | | | | |
|---------------|-------|------|---|----------|--------|-------|------|---|----------|
| H 58 | 2 | 10 | 0 | S.B. 156 | H 407 | 19 | 10 | 0 | S.B. 250 |
| H 68* | | | | H 22 | H 408 | 0 | 10 | 0 | S.B. 250 |
| H 93 | Withd | rawn | | H 6 | H 415 | 81 | 0 | 0 | S.B. 156 |
| H 107 | 10 | 0 | 0 | | H 416* | | | | H 18 |
| H 113 | Withd | rawn | | H 16 | H 435 | | 0 | 0 | S.B. 156 |
| H 114 | Withd | rawn | | H 16 | H 436 | 28 | 0 | 0 | S.B. 156 |
| H 121* | | | | H 22 | H 445 | Withd | rawn | | H 3 |
| H 143 | 252 | 0 | 0 | H 8 | H 455 | 2 | 10 | 0 | H 11 |
| H 144-5* | | | | H 16 | H 456 | 10 | 10 | 0 | H 11 |
| H 170 | Withd | rawn | | H 6 | H 461 | Withd | rawn | | H 2 |
| H 181* | | | | | H 462 | 140 | 0 | 0 | S.B. 250 |
| H 190* | | | | H 17 | H 464 | Withd | rawn | | H 3 |
| H 197* | | | | H 14 | H 466 | Withd | rawn | | H 3 |
| H 202-5 | Withd | rawn | | H 22 | H 467 | Withd | rawn | | H 3 |
| H 207 | 45 | 0 | 0 | S.B. 243 | H 469 | Withd | rawn | | H 3 |
| H 267* | | | | S.B. 156 | H 470 | Withd | rawn | | H 3 |
| H 291-2 each | 4 | 0 | 0 | S.B. 156 | H 471 | 1 | 10 | 0 | H 4 |
| H 298 | 35 | 0 | 0 | S.B. 243 | H 474 | 2 | 10 | 0 | H 11 |
| H 319-20 each | 2 | 16 | 0 | S.B. 156 | H 476 | 6 | 3 | 0 | S.B. 250 |
| H 372 | 4 | 0 | 0 | S.B. 156 | H 477 | 6 | 0 | 0 | S.B. 250 |
| H 381 | 2 | 10 | 0 | S.B. 156 | H 478 | 2 | 10 | 0 | H 11 |
| H 383 | Withd | rawn | | H 6 | H 490 | 0 | 10 | 9 | S.B. 250 |
| H 384 | 259 | 0 | 0 | H 9 | H 491 | | | | S.B. 250 |
| H 386* | | | | S.B. 156 | H 496 | | | | S.B. 250 |
| H 387 | 3 | 3 | 0 | H 8 | H 500 | 30 | 0 | 0 | S.B. 156 |
| H 388 | 0 | 7 | 6 | H 8 | H 502 | 15 | 0 | 0 | S.B. 208 |
| H 400 | Withd | rawn | | H 2 | H 507 | 0 | 10 | 0 | S.B. 250 |
| H 406 | 30 | 0 | 0 | H 20 | | | | | |

* Prices quoted on application

| Catalogue Number | | Price | | | Catalogue Page | Catalogue Number | | Price | | | Catalogue Page |
|------------------|---|-------|------|----|----------------|------------------|-------|-------|---|--|----------------|
| | | £ | s. | d. | | £ | s. | d. | | | |
| L 1 | . | 98 | 0 | 0 | L 6 | L 36-7 | Withd | rawn | | | L 12 |
| L 6 | . | 10 | 10 | 0 | L 11 | L 41 | Withd | rawn | | | L 12 |
| L 12 | . | 235 | 0 | 0 | L 6 | L 45* | | | | | L 7 |
| L 17 | . | 110 | 0 | 0 | L 6 | L 49 | 4 | 10 | 0 | | L 11 |
| L 24 | . | Withd | rawn | | L 12 | L 50 | 280 | 0 | 0 | | L 3 |
| L 27 to 31 | . | Withd | rawn | | L 12 | L 75* | | | | | S.B. 230 |
| L 33 | . | 2 | 2 | 0 | L 12 | L 77* | | | | | L 4 |

CATALOGUE M

| | | | | | | | | | | |
|--------|---|-------|------|---|------|--------------|-------|------|---|----------|
| M 24* | . | | | | M 6 | M 206 | 4 | 10 | 0 | M 21 |
| M 26* | . | | | | M 6 | M 216* | | | | M 21 |
| M 48 | . | Withd | rawn | | M 4 | M 246 | 11 | 0 | 0 | M 21 |
| M 57-8 | . | Withd | rawn | | M 4 | M 247 | 11 | 10 | 0 | M 21 |
| M 73 | . | Withd | rawn | | M 4 | M 251 | 12 | 0 | 0 | M 21 |
| M 75* | . | | | | M 8 | M 284* | | | | M 14 |
| M 106 | . | 5 | 10 | 6 | M 17 | M 288 | Withd | rawn | | M 4 |
| M 120 | . | 1 | 15 | 0 | M 21 | M 289 | 4 | 5 | 0 | M 21 |
| M 121 | . | 2 | 0 | 0 | M 21 | M 291 | 1 | 13 | 0 | M 21 |
| M 122 | . | 2 | 0 | 0 | M 21 | M 292 | 1 | 15 | 0 | M 21 |
| M 123 | . | 2 | 0 | 0 | M 21 | M 295* | | | | M 12 |
| M 124 | . | 2 | 5 | 0 | M 21 | M 296* | | | | M 12 |
| M 148* | . | | | | M 16 | M 298* | | | | M 18 |
| M 154* | . | | | | M 9 | M 309 | Withd | rawn | | M 4 |
| M 166* | . | | | | M 24 | M 313 | 4 | 5 | 0 | M 21 |
| M 169* | . | | | | | M 314 | 1 | 10 | 0 | M 21 |
| M 170* | . | | | | | M 315 | 1 | 15 | 0 | M 21 |
| M 171* | . | | | | | M 320 | 49 | 0 | 0 | M 20 |
| M 180* | . | | | | | M 322* | | | | M 11 |
| M 181* | . | | | | | M 331 | 6 | 6 | 0 | M 19 |
| M 182* | . | | | | | M 332* | | | | |
| M 191 | . | 38 | 10 | 0 | M 20 | M 334 | 120 | 0 | 0 | M 26 |
| M 192 | . | 39 | 10 | 0 | M 20 | M 335* | | | | M 14 |
| M 194 | . | 41 | 10 | 0 | M 20 | M 356 | 4 | 15 | 0 | S.B. 242 |
| M 195 | . | 5 | 0 | 0 | M 20 | M 357-9 each | 5 | 0 | 0 | S.B. 242 |
| M 204 | . | 4 | 0 | 0 | M 21 | M 360 | 5 | 5 | 0 | S.B. 242 |
| M 205 | . | 4 | 0 | 0 | M 21 | | | | | |

CATALOGUE N

| | | | | | | | | | | |
|-------|---|--------------|--------|---|-----|--------|----|----|---|------|
| N 4 | . | 23 | 0 | 0 | N 6 | N 50/4 | 20 | 0 | 0 | N 12 |
| N 9 | . | 15 | 0 | 0 | N 6 | N 52* | | | | N 9 |
| N 21 | . | not supplied | singly | | N 8 | N 68 | 60 | 0 | 0 | N 2 |
| N 23 | . | 7 | 10 | 0 | N 8 | N 79 | 60 | 0 | 0 | N 3 |
| N 25 | . | 11 | 10 | 0 | N 8 | N 80 | 60 | 0 | 0 | N 3 |
| N 32 | . | 155 | 0 | 0 | N 7 | N 83 | 60 | 0 | 0 | N 3 |
| N 33 | . | 165 | 0 | 0 | N 7 | N 116 | 11 | 10 | 0 | N 8 |
| N 34 | . | 185 | 0 | 0 | N 7 | N 117 | 11 | 10 | 0 | N 8 |
| N 48† | . | 54 | 0 | 0 | N 4 | | | | | |

† Now includes F 7, F 8, and F 13 formerly separate

CATALOGUE P

| | | | | | | | | | | |
|------|---|----|----|---|-----|-------|----|----|---|-----|
| P 65 | . | 7 | 0 | 0 | P 5 | P 69 | 12 | 10 | 0 | P 5 |
| P 66 | . | 8 | 0 | 0 | P 5 | P 70 | 17 | 0 | 0 | P 5 |
| P 67 | . | 9 | 0 | 0 | P 5 | P 71 | 24 | 0 | 0 | P 5 |
| P 68 | . | 10 | 10 | 0 | P 5 | P 164 | 0 | 7 | 6 | P 8 |

* Prices quoted on application

| Catalogue Number | Price | | | Catalogue Page | Catalogue Number | Price | | | Catalogue Page |
|---------------------|-------|----|----|-------------------|---------------------|-------|----|----|-------------------|
| | £ | s. | d. | | | £ | s. | d. | |
| T 131 . . . | 38 | 0 | 0 | S.B. 216 | T 173 . . . | 15 | 0 | 0 | S.B. 239 |
| T 136 . . . | 200 | 0 | 0 | S.B. 239 | T 174 . . . | 15 | 0 | 0 | S.B. 239 |
| T 172 . . . | 15 | 0 | 0 | S.B. 239 | T 180 . . . | 60 | 0 | 0 | S.B. 239 |

ADAM HILGER, LTD.,

WORKS, LABORATORIES AND SHOWROOMS

98 KINGS ROAD, CAMDEN ROAD, LONDON, N.W.1

Telephone No.: GULLIVER 5426

Telegraphic Address: Sphericity, 'Phone, London
(Charged as two words only)

PRINTED IN GREAT BRITAIN

H 1000/2037/9/57